



INTEGRATED FLOW SOLUTIONS

www.IFSolutions.com

AQAM Series Aqueous Ammonia Unloading Station

Integrated Flow Solutions AQAM Series Aqueous Ammonia Unloading Stations are designed to unload 19% & 29% Aqueous Ammonia from transports into a modular Storage/Forwarding System which includes a storage tank, forwarding pump system, instrumentation, & controls. The complete system is designed to minimize field assembly. The forwarding system is designed to transfer the Aqueous Ammonia to the Ammonia Flow Control Unit (AFCU).

Industries



Applications – See industry tab

Benefits:

- Single Source Accountability
- Pre-Packaged Modular Design Costs Less than component based site built which reduces overall project cost
- Minimizes field erection time – shorter overall project delivery schedule
- Complete system function testing prior to shipment
- 24/7 Customer service

Industry Standards

- Vessels code stamped ASME Section VIII & National Board Registered
- Piping designed to ANSI B31.1/ANSI B31.3
- Pipe fabrication to ASME Section IX
- Structural Steel Assembly Designed to AWS D1.1
- Complete system designed to API RP 550

Standard Features:

- FlowSafe Unloading Station
 - Local indication of:
 - Tank level
 - Flow indication
 - Local manual/automated valve operation
- Storage/Forwarding System
 - Vessel storage up to 30,000 gallons
 - Vessel material options:
 - Carbon Steel or 304L
 - Heavy duty forwarding pumps to meet any hydraulic or NPSHA condition:

Standard Features (cont.):

- Centrifugal/Gear/Regen Turbine/Mag drive & canned motor
 - Locally Mounted Control Panel
- Complete factory function test

Optional Features:

- Separate Skid Mounted Pump Forwarding System
- Unloading Breakaway Couplings
- PLC Based and Full VFD Control Panel per NEC & NFPA
- UL or CSA Listed Control Panel Assembly
- Complete Factory Performance Test
- Class 1, Div 2 Hazardous Locations
- Compliance with Plant/Engineering Specifications

Additional Services:

- “Aspen Plus” Process Simulation Software used to guarantee process conditions
- Installation / Training / Start – Up Supervision
- Extended warranty
- Nationwide Service Network

Aqueous Ammonia Unloading Station & Storage/Forwarding System

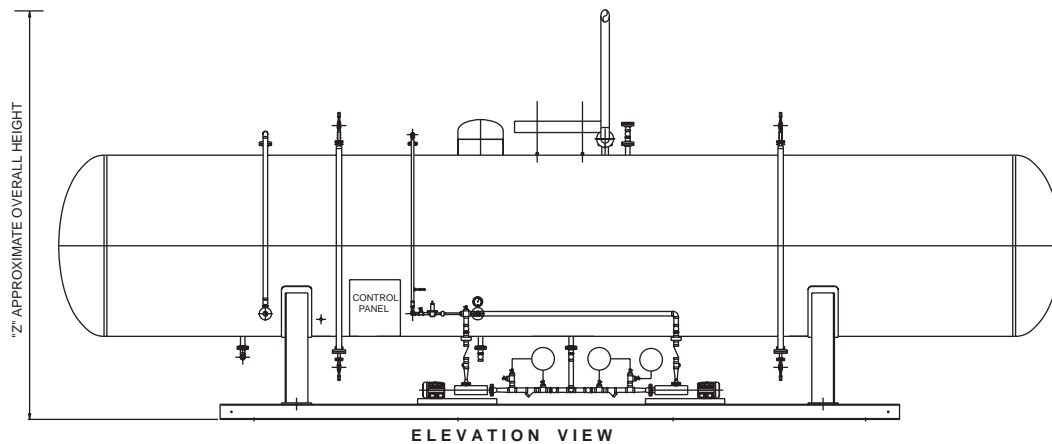
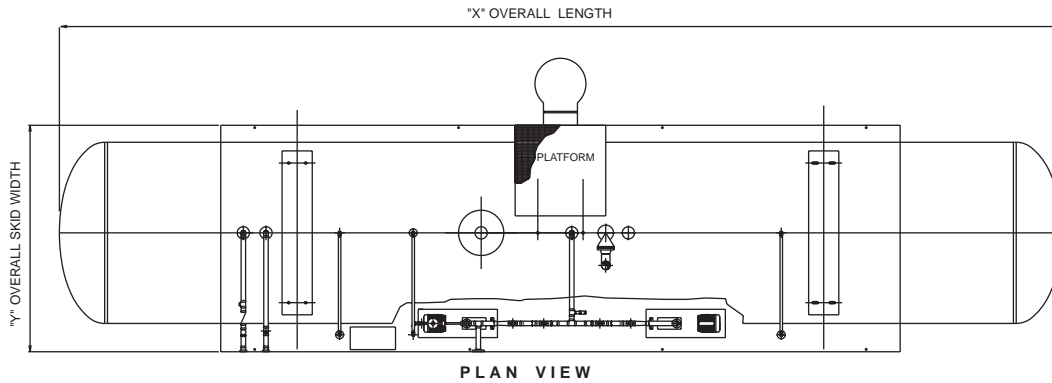
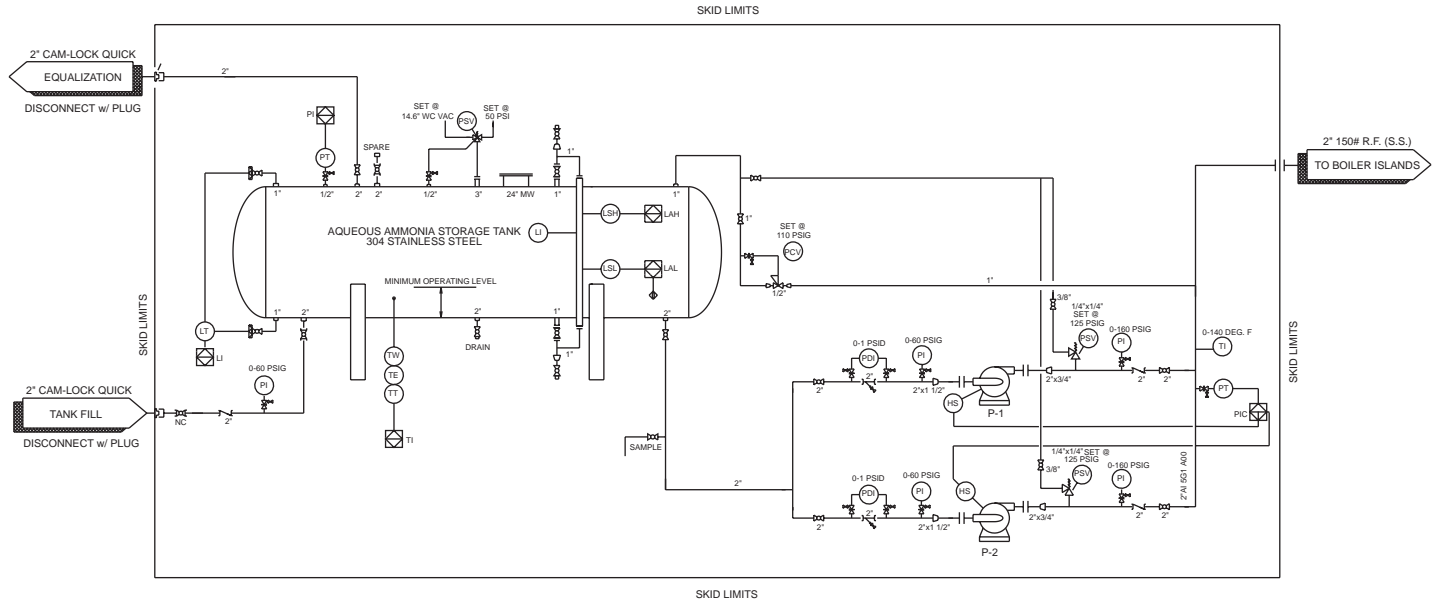

WORKING VOLUME - GALLONS	LENGTH - X	WIDTH - Y	HEIGHT - Z	WEIGHT - LBS.
6,000	20'	11'	14'	15,000
10,000	34'	11'	14'	25,000
14,000	50'	11'	14'	35,000
18,000	60'	11'	14'	45,000
22,000	75'	12'	16'	55,000