



INTEGRATED FLOW SOLUTIONS

Hot Coke Gas Oil Filtration Packages

Integrated Flow Solutions Hot Coke Gas Oil Filtration Packages are designed to filter particulate from the heavy coker gas oil before entering the catalytic cracker. IFS HCGO Filter Packages extend the life of the catalyst and reduces catalyst regeneration cycles.

Industries



Applications for IFS HCGO Filter Systems

- Petroleum Refineries
- Coker Plants

Features of IFS HCGO Filter Systems

- Flexibility – Patented Filtration Pack
 - Filters sponge, shot, needle coke
- Depressurization Safety
- Large blow down opening
- Maintainability – Filter pack mounted to closure
- Low Pressure Drop – Channeled inward flow with low clean and dirty pressure drop
- Process Guarantee
- Factory Trained/Certified Technicians
- 24/7 USA Customer service (800-527-8724)

Industry Standards

- Filter vessels code stamped ASME Section VIII, Div. 1 & National Board Registered
- Piping Designed to ANSI B31.1 / B31.3
- Pipe Fab to ASME Section IX
- ISO 9001 : 2008

Benefits of IFS HCGO Filter Systems:

- Longer catalyst life
- Lower operating cost
- Low Maintenance
- Longevity
 - Extended filtration surface area
 - Requires fewer back flush cycles

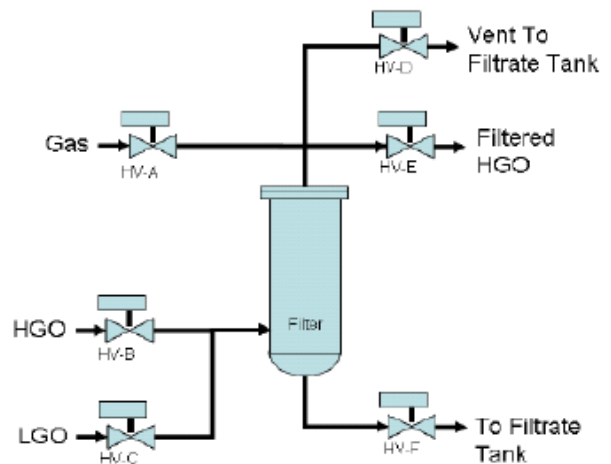

Hot Coke Gas Oil Filtration Package

