



# Integrated Flow Solutions

Modular Liquid & Gas Process Systems

## IFS 2019 Company Profile





**COMPANY PROFILE**

◆ **Full Company Name and Address**

<u>Sales &amp; Marketing</u>	<u>Engineering &amp; Manufacturing</u>
Integrated Flow Solutions, LLC	Integrated Flow Solutions, LLC
9807 Whithorn Drive	6461 Reynolds Road
Houston, Texas 77095	Tyler, Texas 75708

◆ **Mailing Address**

9807 Whithorn Drive	P. O. Box 7095
Houston, Texas 77095	Tyler, Texas 75711
Telephone 281-855-8125	Telephone 903-595-6511
Facsimile 281-855-3504	Facsimile 903-595-4774
Website: <a href="http://www.ifsolutions.com">www.ifsolutions.com</a>	Email <a href="mailto:sales@ifsolutions.com">sales@ifsolutions.com</a>

◆ **Remit / Payment Address**

Integrated Flow Solutions, LLC
P. O. Box 7095
Tyler, Texas USA 75711

Type of Ownership:	Public
Owner:	DXP Enterprises
Year of Incorporation	1979
Government Classification:	Limited Liability Corporation
Type of Business:	Engineered To Order Gas & Liquid Process Solutions
Annual Sales:	Integrated Flow Solutions LLC
2013	\$70.0MM
2014	\$41.5MM
2015	\$35.5MM
2016	\$32.0MM
2017	\$22.0MM
2018	\$34.0MM
Dun & Bradstreet Number:	80-349-9961
Federal ID Number:	01-0727249
Texas Direct Pay Number:	1-75-2349067-4



**Integrated Flow  
Solutions LLC**  
A **DXP** Company

## COMPANY PROFILE

Integrated Flow Solutions, LLC (IFS) specializes in the design and manufacture of “engineered to order” & “configure to order” liquid and gas handling process systems for a variety of industries. Founded in 1979 as an outgrowth of the pump distribution business, IFS began serving the oil and gas market, then expanded into power generation, air quality and general industrial. In 2014, IFS and Best PumpWorks were acquired by DXP Enterprises, a Houston, Texas based public company.



**Integrated Flow  
Solutions LLC**  
A **DXP** Company

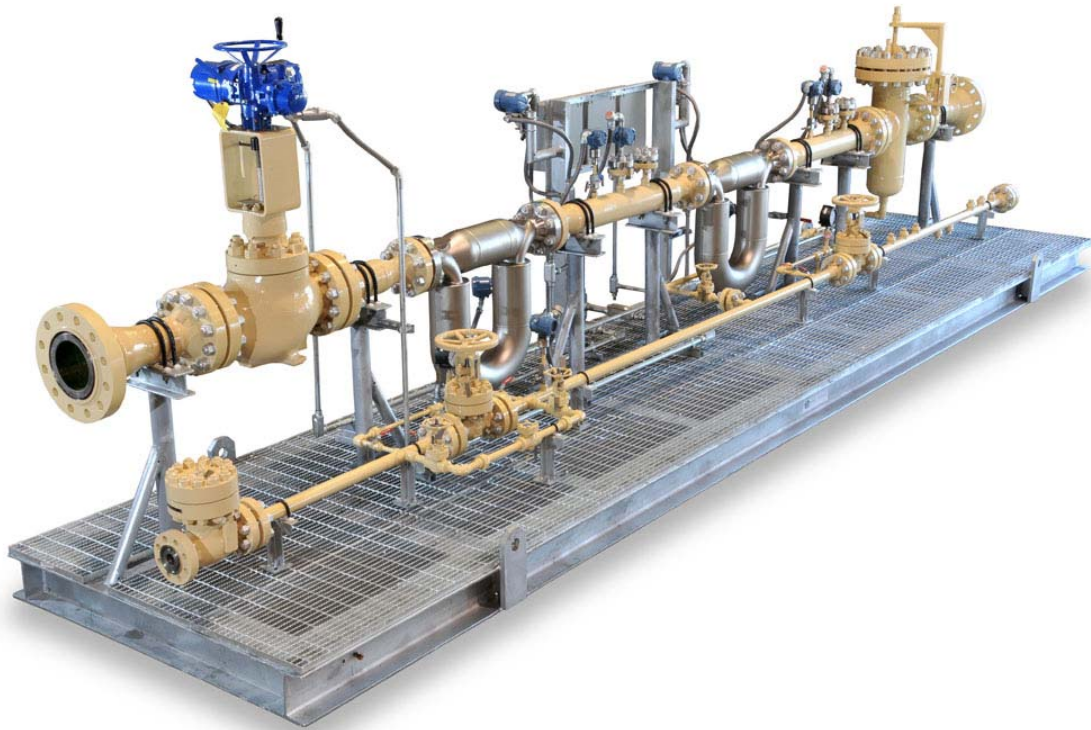

MODULAR METERING PACKAGE



## COMPANY PROFILE

### NUMBER OF IFS EMPLOYEES

◆ <b><u>Overall Number of Employees</u></b>	97
1. Company Management:	<u>Houston, Texas</u>
President	William H. Marsh
VP Sales	Juan Carlos Patino
	<u>Tyler, Texas</u>
Operations Manager	Steve Ramsey
Project Management Team	Dave Pollan
	Troy Urbantke
	Sagar Mylabathula
	William Shepherd
	Phillip Grisham
	Marlin Sinville
Engineering Manager	Leandro Bruno
Product Support Manager	Larry Dalrymple
Quality Control Manager	Kevin Tuohy
Materials Manager	Timmie Howell
Documentation Manager	Eduardo Lesser
2. Engineering:	
Mechanical Engineers	10
Electrical Engineers	3
Process Engineers	3
Designers	4
Draftsmen	6
3. Product Support:	4
4. Purchasing:	5
5. Quality Control:	5
6. Shop:	
Number of Supervisors	5
Number of Inspectors	1
Average Number of All Production Workers	50
Average Number of Code Welders	15
Painters	3
Instrument Fitters	7

## COMPANY PROFILE

A sample of the IFS Product Line includes:

<b>POWER AIR QUALITY</b>	<b>UPSTREAM OIL &amp; GAS</b>	<b>MIDSTREAM OIL &amp; GAS</b>	<b>DOWNSTREAM OIL &amp; GAS</b>
Fuel Gas Cond. Packages	Wellhead Fuel Gas Conditioning Package	LACT Units ACT Units	Coker Filtration Packages
Black Powder Filtration Packages	Production De sanding Packages	Hydrocarbon Metering Packages	Burner Fuel Gas Conditioning Packages
Pressure Reduction Packages	Crude Oil Pipeline Pump Packages	Pipeline Pump Packages	Lube Oil Blending Packages
Ammonia Storage, Unloading & Forwarding Packages	Water Injection Pump Packages	Line Heater Packages	Process Fluid Heating Packages
Ammonia Flow Control Units	Nitrogen Generation Packages	Pressure Regulator Packages	SCR Support Packages

### Tyler, TX Facility



125,000 Square Feet Under Roof Located on 7 Acres  
 100 Full Time Employees  
 20 Overhead Cranes  
 26' Under Hook Height

◆ **Facilities**

1. Building Bays & Crane Capacities:

<u>Bay Dimen.</u>	<u>Use</u>	<u>Crane</u>	<u>No.</u>	<u>Capacity</u>	<u>Hook Height</u>
125' x 60'	Fab	Overhead	2	20 Ton	20'
110' x 50'	Assy	Overhead	2	25 Ton	20'
154' x 50'	Mech	Overhead	2	3 Ton	13'
154' x 50'	Mech	Overhead	2	3 Ton	10'
80' x 30'	Fab	Overhead	2	3 Ton	10'
100' x 25'	Fab	Jib	8	5 Ton	18'
125' x 60'	Pipe Weld	Overhead	2	5 Ton	20'

2. Administration/Warehouse – 20,000 Square Feet Truck Shipping & Receiving

3. Coatings:

- Enclosed Grit Blasting 20' x 38' x 12'
- Enclosed Heated Paint Booth 20' x 48.5' x 16'
- Enclosed Paint Booth 12' x 12' x 8'
- Outdoor Sand Blasting Pad

4. Maximum Size & Weight of Fabricated Units Inside the Shops Only  
24' Wide by 25' High at 100,000 Pounds Maximum

Major Fabrication Equipment

<u>Equipment Type</u>	<u>Qty.</u>	<u>Size or Capacity</u>
Union Horizontal Boring Mill	1	5"
Summit Horizontal Boring Mill	1	4"
Muzak Lathe	1	34" x 120"
Muzak Lathe	1	18" x 60"
Clausing/Colchester Lathe	1	18" x 80"
Victor Lathe	1	20" x 80"
Precision Vertical Mill	1	15" x 52"
Nardini Lathe	1	21" x 120"
Promaster Lathe	1	17" x 80"
Planer Mill	1	42" x 20"
Radial Arm Drill	1	
Abrasive Cut Off Machine	1	20"
Johnson Band Saw	2	3/4" x 37"
Wire Feed Welding Machines	19	300 to 400
Manual Welding Machines	7	400 Amp
CM-2040 13B Beam Profile Machine	1	
Magnatech Pipeline II Welding System	1	
Iron Worker	1	90 Ton
Plasma Cutting Equipment	2	
Pipe Positioner	1	1-1/2 Ton
Track Torch	2	
Ludeca Optalign Plus Laser Shaft/Coupling Alignment Tool	1	
IRD 290 Rotor Balancer	1	
IRD 885 Vibration Analyzer	1	
TN Model 9277 Metal Analyzer		
Hydrotest Equipment	1	30,000 PSI
Hydrotest Equipment	2	10,000 PSI

**Material Fabrication Capabilities & Limitations**

IFS Welding Experience: IFS employs code welders for structural, pipe & vessel welding. The table below summarizes IFS's welding capabilities in ASME P Numbers, thicknesses, welding processes, and no. of certified welders for each process.

Material (P No.)	Thickness Range (inches)	Process	No. of Welders & Code
P No. 1 to P No. 1	0.063" to 0.96"	GTAW	(9) ASME B&PVC Section IX
P No. 1 to P No. 1	0.094" to 1.757"	GMAW-S / GMAW-P	(7) ASME B&PVC Section IX
P No. 1 to P No. 1	0.094" to 0.864"	FCAW	(4) ASME B&PVC Section IX
P No. 1 to P No. 1	0.063" to 1.27"	SMAW	(4) ASME B&PVC Section IX
P No. 1 to P No. 1	0.188" to 2"	SAW	(1) ASME B&PVC Section IX
P No. 1 to P No. 8	0.063" to 0.56"	GTAW	(9) ASME B&PVC Section IX
P No. 1 to P No. 8	0.063" to 0.638"	GMAW-S	(7) ASME B&PVC Section IX
P No. 1 to P No. 8	0.063" to 0.638"	FCAW	(4) ASME B&PVC Section IX
P No. 8 to P No. 8	0.063" to 2"	GTAW	(9) ASME B&PVC Section IX
P No. 8 to P No. 8	0.063" to 2"	GMAW-S / GMAW-P	(7) ASME B&PVC Section IX
P No. 8 to P No. 8	0.063" to 0.56"	FCAW	(4) ASME B&PVC Section IX
P No. 8 to P No. 8	0.063" to 0.75"	SMAW	(4) ASME B&PVC Section IX
P No. 8 to P No. 43	0.063" to 0.266"	GTAW	(9) ASME B&PVC Section IX
P No. 42 to P No. 42	0.120" to 0.48"	GTAW	(9) ASME B&PVC Section IX
P No. 10H to P No. 10H	0.063" to 0.75"	GTAW	(9) ASME B&PVC Section IX
AWS Group I & II	0.125" to Unlimited	GMAW-S	(3) AWS D1.1
AWS Group I & II	0.125" to Unlimited	FCAW	(6) AWS D1.1
CSA Group 1, 2, & 3	0.125" to Unlimited	FCAW	(3) CSA W47.1 & W59

**Industry Standard Codes**

Vessels code stamped ASME Sections VIII & National Board Registered  
Piping designed to ANSI B31.1 or B31.3  
Piping fabricated to ASME Section IX  
Structural Steel Assembly Designed to AWS D1.1  
SSPC Systems and Specifications  
UL Electrical Control Panel Construction

**Certifications:**

ASME Code Stamp Certificates U & S  
National Board Certificate (NB) & R  
Canadian Welding Bureau (CWB)  
CSA Certificate of Compliance  
UL Panel Shop Certificate  
IEC Control Panel Certification  
CE/ATEX Declaration of Conformity  
PED Certificate of Conformity  
ATEX Electrical Construction  
GOST-R Certificate of Conformity  
ISO 9001:2015



**Engineering & Design Software:**

ASPEN Plus

ASPEN Hysys

ASPEN EDR

Process Simulations

Process Simulations

Heat Exchangers sizing

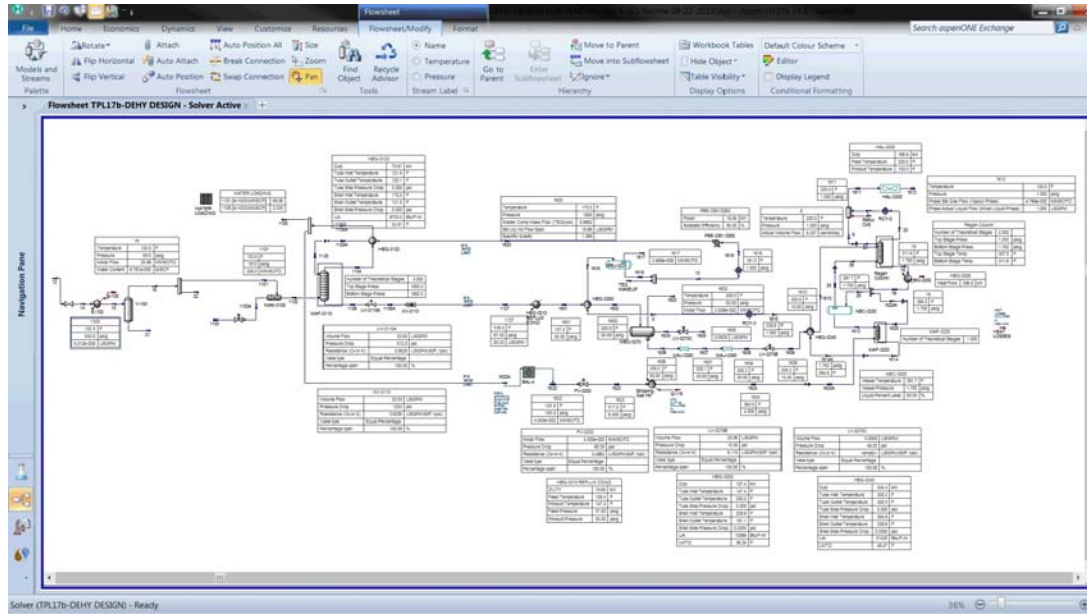

Codeware Compress

ASME Vessel Calculations

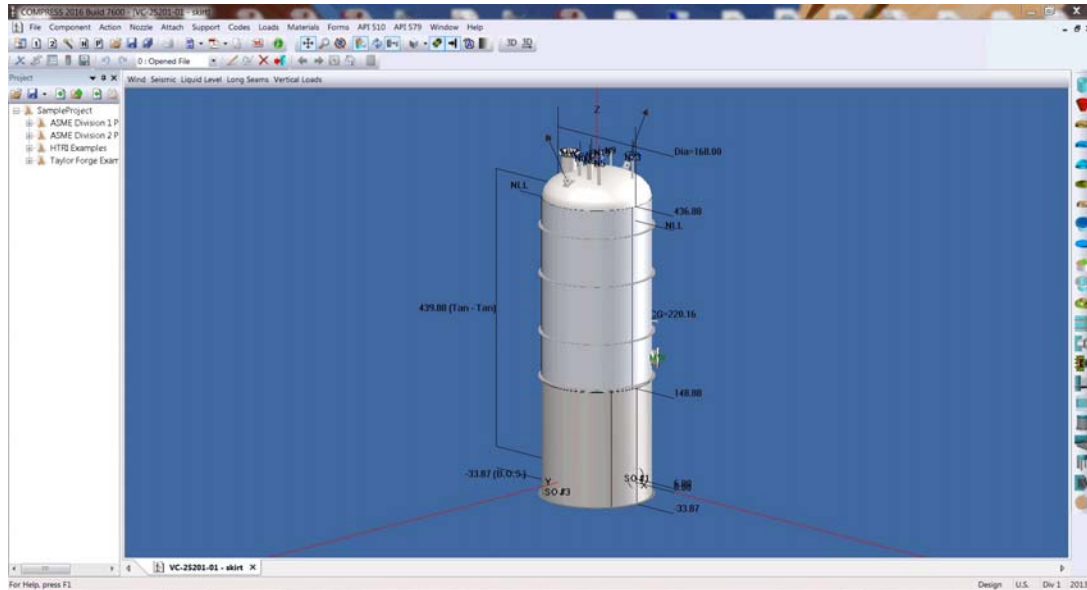



RISA 3D

Structural Analysis

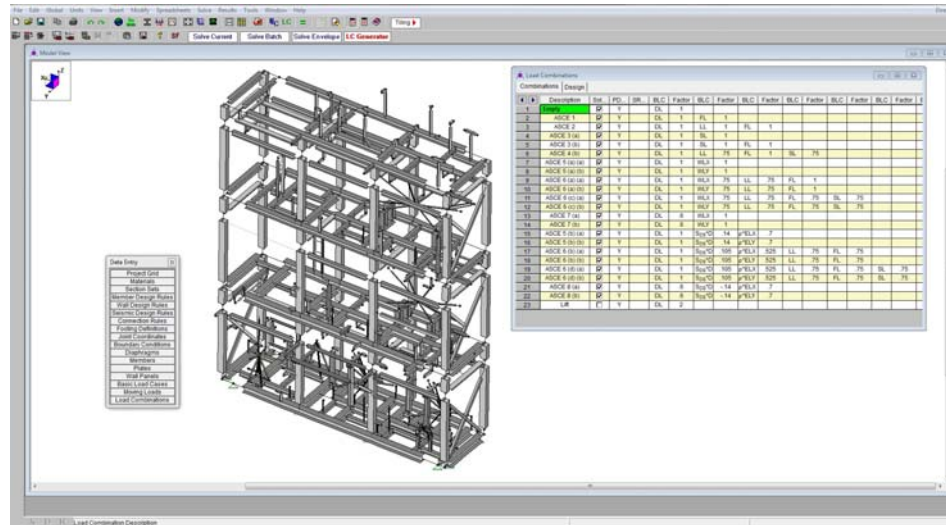

COADE CAESAR II

Pipe Stress Analysis

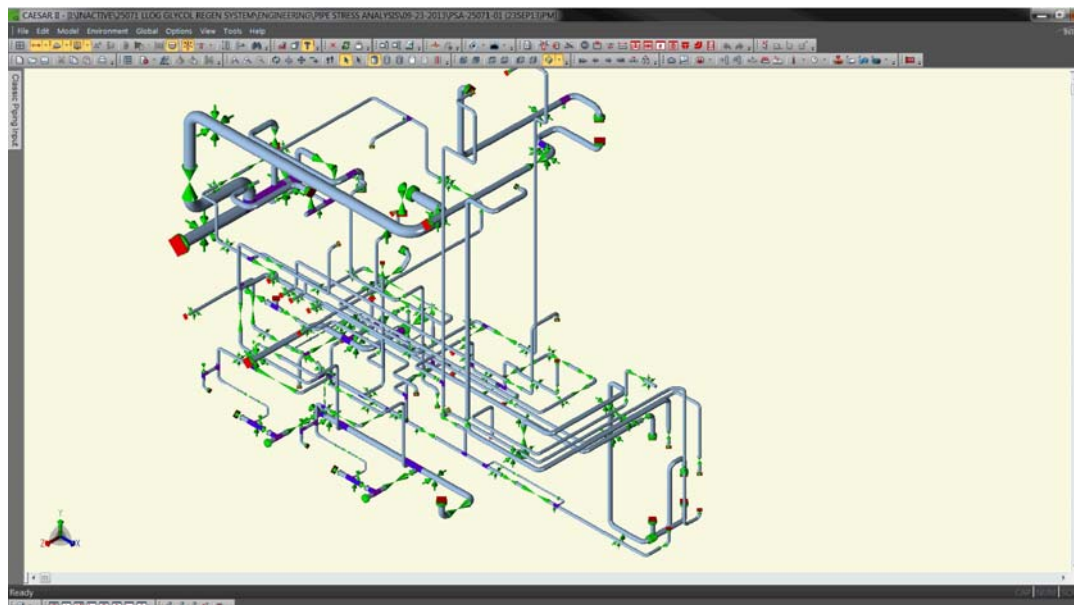

CADWorx

Plant 3D Modeling / Design



**SELECTED MAJOR PROJECTS**



**Ammonia Flow Control Package**  
**Customer: San Diego Gas & Electric**



**Ammonia Flow Control Package**  
**Customer: Sunoco Refinery**



**Intercooler Water Circ. Package**  
**Customer: GE/Basin Electric**



**Chemical Injection Packages**  
**Customer: Petrobras**



**Water Injection Pump Package**  
**Customer: Chevron**



**Chemical Injection Packages**  
**Customer: Chevron**

Helpful Links:

OSHA - 300 Form Directions: <https://www.osha.gov/recordkeeping/RKforms.html>

Save

OSHA - Recording and Reporting Occupational Injuries and Illness <http://www.osha.gov/pls/oshaweb/ow>

If your company is not required to maintain OSHA logs, please complete this form and upload in the below question 3). <http://www.pecdata.com/SSQV4/FileProcessing.ashx?DocumentID=3980322>

1a. Are employees from other offices / districts ever utilized?

Yes  No

1b. If an employee from another office / district is injured, at which office / district is their injury recorded?

2a. List Incident Details for each QTR:

INSTRUCTIONS:

- In the table below, provide the current year-to-date and the last 3 full years of incident information for your company.
  - Click the EDIT button to edit a row and the SAVE button to save your edits.
  - Count ALL employees, including administrative and corporate offices.
  - All editable OSHA columns **MUST** be zero or a positive number.
  - The section will remain incomplete until the table is completed.
- Once data has been verified by PEC, the rows will lock.

NOTE: If your company performs work on an offshore facility/lease site under jurisdiction of the Bureau of Safety and

If OSHA does not apply to your company, you are still required to complete the table.

- Print and sign the "OSHA- EXEMPTION LETTER" at the top of this section.
- Upload the form in each of the applicable years in the upload question below this table.

Need Help?

		Recordable Cases									
		Average Number of Employees	Exposure Hours	Fatalities	Away From Work/Lost Time Cases	Remained At Work		Other Recordable Cases	Total Recordable Cases (Calculated)	Nonfatal Incident Rate	Re I (Ca
Year	Quarter					Job Transfer/Restricted/Modified Work Cases	Work Cases				
Edit	2018	3	127	72378	0	0	0	0	0	0	
Edit	2018	2	121	58070	0	0	0	0	0	0	
Edit	2018	1	117	71640	0	0	0	1	1	0.70	
	Summary	2018	122	202088	0	0	0	1	1	0.99	
	2017	4	108	55910	0	0	0	0	0	0	
	2017	3	90	31526	0	0	0	0	0	0	
	2017	2	90	48419	0	0	0	0	0	0	
	2017	1	87	52610	0	0	0	0	0	0	
	Summary	2017	94	188465	0	0	0	0	0	0	
	2016	4	127	46133	0	0	0	0	0	0	
	2016	3	130	55614	0	0	1	0	1	0.90	
	2016	2	128	70480	0	0	0	1	1	0.71	
	2016	1	127	65807	0	1	0	0	1	0.76	
	Summary	2016	128	238034	0	1	1	1	3	2.52	

2015	4	134	76676	0	0	0	0	0	0
2015	3	130	67337	0	0	0	1	1	0.74
2015	2	133	74092	0	0	0	0	0	0
2015	1	130	62229	0	0	0	1	1	0.80
Summary	2015	132	280334	0	0	0	2	2	1.43

2b. Three Year Summary

This table is a summary of the latest three calendar years. The year shown in the first column is the latest year in which is the most recent completed quarter.

Latest Complete Year	Latest Complete Quarter	Average Number of Employees	Exposure Hours	Fatalities	Away From Work/Lost Time Cases	Recordable Cases		Total Recordable Cases (Calculated)	Total Recordable Incidents (Calculated)
						Remained At Work			
						Job Transfer/Restricted/Modified Work Cases	Other Recordable Cases		
2017	Q3 2018	118.00	706833.00	0.00	1.00	1.00	3.00	5.00	1

3. OSHA Verification Documents

Upload OSHA 300A and 300 logs for the years below. These documents will be locked once verified by a PEC Representative

Year	OSHA Verification
2017	<a href="#">Review Uploaded Documents</a>
2016	<a href="#">Review Uploaded Documents</a>
2015	<a href="#">Review Uploaded Documents</a>

4. Please enter any comments below on information in the incident tables: This information should include how many employees

2Q2011 - Hand Laceration and foreign object in eye  
 1Q2011 - Bruised Leg  
 1Q10 - Foreign substance in eye  
  
 1Q 2004 Foreign object in eye  
 3Q 2004 Foreign object in eye.  
 1Q 2006 disputed case - back injury  
 2Q 2006 foreign object in eye  
 4Q06 grit in eye

5. Does your company include hours worked by subcontractors in reporting?

Yes  No  NA

6a. Specify the basis for exposure or employee hours.

10 Hr. Shifts

6b. If "Other" above, please explain the basis for exposure or employee hours.



# CERTIFICATE OF LIABILITY INSURANCE

DATE (MM/DD/YYYY)

6/7/2018

THIS CERTIFICATE IS ISSUED AS A MATTER OF INFORMATION ONLY AND CONFERS NO RIGHTS UPON THE CERTIFICATE HOLDER. THIS CERTIFICATE DOES NOT AFFIRMATIVELY OR NEGATIVELY AMEND, EXTEND OR ALTER THE COVERAGE AFFORDED BY THE POLICIES BELOW. THIS CERTIFICATE OF INSURANCE DOES NOT CONSTITUTE A CONTRACT BETWEEN THE ISSUING INSURER(S), AUTHORIZED REPRESENTATIVE OR PRODUCER, AND THE CERTIFICATE HOLDER.

**IMPORTANT:** If the certificate holder is an ADDITIONAL INSURED, the policy(ies) must have ADDITIONAL INSURED provisions or be endorsed. If SUBROGATION IS WAIVED, subject to the terms and conditions of the policy, certain policies may require an endorsement. A statement on this certificate does not confer rights to the certificate holder in lieu of such endorsement(s).

<b>PRODUCER</b> Marsh & McLennan Agency LLC 2500 City West Boulevard, Suite 2400 Houston TX 77042	<b>CONTACT NAME:</b> Patsy Howard <b>PHONE (A/C. No. Ext):</b> 713-780-6620 <b>E-MAIL ADDRESS:</b> patsy.howard@marshmma.com		<b>FAX (A/C. No.):</b> 212-948-6320
	<b>INSURER(S) AFFORDING COVERAGE</b>		
<b>INSURED</b> Integrated Flow Solutions, LLC P.O. Box 7095 Tyler TX 75711	DXPEN-1		<b>INSURER A:</b> Travelers Property Casualty Co of Amer <b>NAIC #</b> 25674
			<b>INSURER B:</b> Navigators Insurance Company <b>NAIC #</b> 42307
			<b>INSURER C:</b> Travelers Indemnity Company <b>NAIC #</b> 25658
			<b>INSURER D:</b> Travelers Prop & Casualty Co of America <b>NAIC #</b> 25674
			<b>INSURER E:</b>
			<b>INSURER F:</b>

**COVERAGES**

CERTIFICATE NUMBER: 1513806238

REVISION NUMBER:

THIS IS TO CERTIFY THAT THE POLICIES OF INSURANCE LISTED BELOW HAVE BEEN ISSUED TO THE INSURED NAMED ABOVE FOR THE POLICY PERIOD INDICATED. NOTWITHSTANDING ANY REQUIREMENT, TERM OR CONDITION OF ANY CONTRACT OR OTHER DOCUMENT WITH RESPECT TO WHICH THIS CERTIFICATE MAY BE ISSUED OR MAY PERTAIN, THE INSURANCE AFFORDED BY THE POLICIES DESCRIBED HEREIN IS SUBJECT TO ALL THE TERMS, EXCLUSIONS AND CONDITIONS OF SUCH POLICIES. LIMITS SHOWN MAY HAVE BEEN REDUCED BY PAID CLAIMS.

INSR LTR	TYPE OF INSURANCE	ADDL INSD	SUBR WVD	POLICY NUMBER	POLICY EFF (MM/DD/YYYY)	POLICY EXP (MM/DD/YYYY)	LIMITS
A	<input checked="" type="checkbox"/> COMMERCIAL GENERAL LIABILITY <input type="checkbox"/> CLAIMS-MADE <input checked="" type="checkbox"/> OCCUR GEN'L AGGREGATE LIMIT APPLIES PER: <input type="checkbox"/> POLICY <input checked="" type="checkbox"/> PRO-JECT <input checked="" type="checkbox"/> LOC <input type="checkbox"/> OTHER:			TJGLSA9366B88918	1/1/2018	1/1/2019	EACH OCCURRENCE \$ 1,000,000 DAMAGE TO RENTED PREMISES (Ea occurrence) \$ 100,000 MED EXP (Any one person) \$ 25,000 PERSONAL & ADV INJURY \$ 1,000,000 GENERAL AGGREGATE \$ 2,000,000 PRODUCTS - COMP/OP AGG \$ 2,000,000 xxxxxxxxxxxxxxxxxxxxxxxx \$ xxxxxxxxxxxxxxxxxxxxxxxx
D	<input checked="" type="checkbox"/> AUTOMOBILE LIABILITY <input checked="" type="checkbox"/> ANY AUTO <input type="checkbox"/> OWNED AUTOS ONLY <input type="checkbox"/> HIRED AUTOS ONLY <input type="checkbox"/> SCHEDULED AUTOS <input type="checkbox"/> NON-OWNED AUTOS ONLY			TC2JCAP9366B92118	1/1/2018	1/1/2019	COMBINED SINGLE LIMIT (Ea accident) \$ 1,000,000 BODILY INJURY (Per person) \$ XXXXXXXXX BODILY INJURY (Per accident) \$ XXXXXXXXX PROPERTY DAMAGE (Per accident) \$ XXXXXXXXX xxxxxxxxxxxxxxxxxxxxxxxx \$ xxxxxxxxxxxxxxxx
B	<input type="checkbox"/> UMBRELLA LIAB <input checked="" type="checkbox"/> EXCESS LIAB <input checked="" type="checkbox"/> OCCUR <input type="checkbox"/> CLAIMS-MADE DED RETENTION \$			HO18EXC894354IV	1/1/2018	1/1/2019	EACH OCCURRENCE \$ 10,000,000 AGGREGATE \$ 10,000,000 xxxxxxxxxxxxxxxxxxxxxxxx \$ xxxxxxxxxxxxxxxx
C	<b>WORKERS COMPENSATION AND EMPLOYERS' LIABILITY</b> ANY PROPRIETOR/PARTNER/EXECUTIVE OFFICER/MEMBER EXCLUDED? (Mandatory in NH) If yes, describe under DESCRIPTION OF OPERATIONS below	Y/N N	N/A	TC2KUB9366B71218	1/1/2018	1/1/2019	<input checked="" type="checkbox"/> PER STATUTE <input type="checkbox"/> OTH-ER E.L. EACH ACCIDENT \$ 1,000,000 E.L. DISEASE - EA EMPLOYEE \$ 1,000,000 E.L. DISEASE - POLICY LIMIT \$ 1,000,000

DESCRIPTION OF OPERATIONS / LOCATIONS / VEHICLES (ACORD 101, Additional Remarks Schedule, may be attached if more space is required)

**CERTIFICATE HOLDER****CANCELLATION**

For Bid Purposes Only  
 P.O. Box 7095  
 Tyler TX 75711

SHOULD ANY OF THE ABOVE DESCRIBED POLICIES BE CANCELLED BEFORE THE EXPIRATION DATE THEREOF, NOTICE WILL BE DELIVERED IN ACCORDANCE WITH THE POLICY PROVISIONS.

AUTHORIZED REPRESENTATIVE

 Brett Herrington

© 1988-2015 ACORD CORPORATION. All rights reserved.

**BUREAU VERITAS**  
Certification



# INTEGRATED FLOW SOLUTIONS LLC

6461 REYNOLDS ROAD  
TYLER, TX 75708 USA

THIS IS A MULTI-SITE CERTIFICATE, ADDITIONAL SITE(S) ARE LISTED ON THE NEXT PAGE(S)

*Bureau Veritas Certification Holding SAS – UK Branch certifies that the Management System of the above organization has been audited and found to be in accordance with the requirements of the management system standards detailed below*

## ISO 9001:2015

*Scope of certification*

### DESIGN, MARKETING, SALES AND MANUFACTURE OF LIQUID AND GAS PROCESS SYSTEMS

Original cycle start date:	June 29 2016
Expiry date of previous cycle:	September 15 2018
Certification / Recertification Audit date:	May 21 2018
Certification / Recertification cycle start date:	November 5 2018
Subject to the continued satisfactory operation of the organization's Management System, this certificate expires on:	June 28 2019

Certificate No. US012398 Version: 1

**Signed on behalf BVCH SAS – UK Branch**

Certification body address: 5<sup>th</sup> Floor, 66 Prescott Street, London E1 8HG, United Kingdom  
Local office: 16800 Greenspoint Park Drive, Suite 300S, Houston, TX 77060

Further clarifications regarding the scope of this certificate and the applicability of the management system requirements may be obtained by consulting the organization. To check this certificate validity please call: +(800) 937-9311



**BUREAU VERITAS**  
Certification



# INTEGRATED FLOW SOLUTIONS LLC

APPENDIX TO CERTIFICATE NO. : US012398-1

## ISO 9001:2015

### *Certified Locations*

SITE	ADDRESS	SCOPE
INTEGRATED FLOW SOLUTIONS – HQ	6461 REYNOLDS ROAD TYLER, TX 75708 USA	DESIGN, MARKETING, SALES AND MANUFACTURE OF LIQUID AND GAS PROCESS SYSTEMS
INTEGRATED FLOW SOLUTIONS-HOUSTON	9807 WHITHORN DRIVE HOUSTON, TX 77095 USA	DESIGN, MARKETING, SALES AND MANUFACTURE OF LIQUID AND GAS PROCESS SYSTEMS

**Certificate No.** US012398      **Version:** 1

**Signed on behalf BVCH SAS – UK Branch**

Certification body address: 5th Floor, 66 Prescott Street, London E1 8HG, United Kingdom  
Local office: 16800 Greenspoint Park Drive, Suite 300S, Houston, Texas USA

Further clarifications regarding the scope of this certificate and the applicability of the management system requirements may be obtained by consulting the organisation. To check this certificate validity please call: +(800) 937-9311



0008



## Dichiarazione CE/ATEX di conformità EC/ATEX Declaration of conformity

Dichiara sotto la propria esclusiva responsabilità che il prodotto:  
*Declare under our own responsibility that the product:*

**Descrizione prodotto:**

*Description of product:* Fuel Gas Conditioning Package

**Tipo e s/n:** AHE

*Type and serial number:* s/n: 24925

**Marcatura:**

*Marking:*

  3G IIA T3

Al quale questa dichiarazione si riferisce, è conforme alla Direttiva Europea 94/9/CE in considerazione delle seguenti norme armonizzate:

*To which this document refers, is in compliance with the European Directive 94/9/EC considering the following harmonized standards:*

EN 1127-1:2007

EN 13463-1:2001

EN 60079-0:2007

EN 60079-14:2007

La valutazione di conformità è stata eseguita in accordo all'Allegato VIII della Direttiva ATEX 94/9/CE.

*The conformity evaluation has been completed according Annex VIII of the ATEX Directive.*

Tyler, TX 2011

  
Leandro Bruno  
Legale Rappresentante  
Legal Representative





## EC DECLARATION OF CONFORMITY

Manufacturer: INTEGRATED FLOW SOLUTIONS, LLC

We hereby declare that the pressure equipment specified below has been designed, manufactured and tested in accordance with the requirements of:

- Pressure Equipment Directive (97/23/EC)

Description of Pressure Equipment:

Model: Fuel Gas Skids  
Serial number(s): 24925-01, 24925-02



Conformity assessment procedure followed:

Module G: Certificate of Conformity  
Category IV

The Notified Body has issued the following EC certificates:

Certificate of Conformity: CE-0041-PED-G-IFS-001-11-USA, CE-0041-PED-G-IFS-002-11-USA

Notified Body: 0041

The Notified body that carried out the inspection:

Bureau Veritas UK Limited  
Parklands  
Wimslow Road  
Didsbury  
Manchester M20 2RE  
United Kingdom

The following Harmonized standards applied: EN-10204:2004

Other technical standards and specifications used: ASME B31.3, CAS-1000-OF-PI-CAL-0001\_C1

Other Community Directives applied:

- ATEX Directive (94/9/EC)

Marking:  3G IIA T3

*Considering the following harmonized standards:*

EN 1127-1: 2007  
EN 13463-1: 2009  
EN 60079-0: 2007  
EN 60079-14: 2007

The conformity evaluation has been completed according Annex VIII of the ATEX Directive.



- Machinery Directive (2006/42/EC)

Description of Product: Fuel Gas skid with Heater Control Panel Tag# 31-H-10A&B and 31-H-12A&B

Type: D1-24925-01 and D6-24925-01

Marking: Supply Voltage: 400VAC; Three-phases; Frequency: 50 Hz;



Short circuit Rating: 40 kAIC; Full Load Current: 290A;

IP degree of protection: IP42

*Considering the following harmonized standards:*

EN 60204-1:2006

Name and address of the person authorized to compile the relevant technical documentation:

Mayra Bruno

38 Fresham Drive

London

SW15 3EA

A handwritten signature in blue ink, appearing to read 'Eric Pink'.

Signed: Eric Pink  
QAQC Manager

Tyler, TX USA. Date: 19-Jul-2011



**CERTIFICATE OF CONFORMITY**  
**Module G - Pressure Equipment Directive 97/23/EC**  
**N° CE-0041-PED-G-IFS-001-11-USA**

We hereby certify that the design, manufacture and testing of the below pressure equipment complies with the applicable Essential Safety Requirements of the Pressure Equipment Regulations 1999 (EC pressure Equipment Directive 97/23/EC).

*Manufacturer (name):*

**Integrated Flow Solutions**

*Address:*

**6461 Reynolds Road  
 Tyler, TX 75708  
 UNITED STATES OF AMERICA**

**EQUIPMENT**

*Item :*

**Skid 31-Z-10 (SN24925-01)**

*Description :*

**Skid 31-Z-10 contains Four sections designated and rated as follows:Section/Rating Service Scope  
 130 barg @ 80 deg C Fuel Gas Piping Spec.E (Class 900) From Tie-In A to 31-H-10A/B (not inclusive),  
 130 barg @ 120C Fuel Gas Piping Spec.E (Class 900) From 31-H-10A/B to Piping Spec. break E/B downstreams PV-03601,2.  
 21 barg @ 100C Fuel Gas Piping Spec.B (Class 300)  
 11 barg @ 100C Fuel Gas Piping Spec.A (Class 150) including the following: Vessels (1 - Fuel Gas Scrubber, 2-Preheaters [including vessels and the heater bundle]),Piping, Valves, and Instrumentation.All pressure vessels in 31-Z-10 are individually CE Marked by subcontractors and itengrated into one assembly. The interconnecting pipingassemblies, safety and pressure accessories are covered for this particular PED documentation.**

**TESTS CARRIED OUT**

*Final tests:*

**Dimensional checks, check of safety device calculations for sizing and relieving capacity, installation and marking, witness hydrostatic test and pneumatic test of piping lines and final test of assembled skids, review material certificates and verify nameplate marking.**

*Remarks -List of enclosures:*

**INFORMATION**

*Trading name of the manufacturer:*

**Integrated Flow Solutions**

*Trading name of the authorized representative:*

**NA**

*Marking :*

**CE 0041 (BVIL notified body number)**

*Nature and location of the affixing of the marking of the equipment:*

**Nameplate with CE Mark is affixed to skid structural member.**

*Year of manufacture :*

**2011**

*Serial number :*

**31-Z-10 (SN24925-01)**

*Essential maximum/minimum allowable limits :*

- *Maximum allowable pressure:*
- *Minimum/maximum allowable temperature:*

**See other information for details.  
 See other information for details.**



**N° CE-0041-PED-G-IFS-001-11-USA**

**FURTHER INFORMATION (where applicable)**

- Volume V of the pressure equipment (l): **NA**
- Nominal size for piping DN: **DN 25 - DN 150**
- Test pressure PT applied (bar) and date: **SN24925-01 Test @ 6.2 barg 15 Feb 2011, See Hydro Test Verification on the 31-Z-10 Inspection Checklist for line hydro tests and dates.**
- Safety device set pressure (bar): **PSV-0601, 0602, 02601 & 02611 @ 129 barg, PSV 06601, 06611, 04601 & 05601 @ 21 barg, PSV 07601 & 08601 @ 10.9 barg**
- Output of the pressure equipment (kW): **NA**
- Supply voltage (volts): **NA**
- Intended use: **Cleaning particulates in gas.**
- Filling ratio (kg/l): **NA**
- Maximum filling mass (kg): **NA**
- Tare mass (kg): **SN24925-01: 33,566 kg**
- Product group: **1 Gas**
- Other information: **SN24925-01:  
(Class 900)Max PS 130 barg @ Max T 80 deg C / -29 deg C Min,  
(Class 900)Max PS 130 barg @ Max T 120 deg C / -29 deg C Min,  
(Class 300) Max PS 21 barg @ Max T 100 deg C / -29 deg C Min,  
(Class 150)Max PS 11 barg @ Max T 100 deg C / -29 deg C Min.**

Made at	On (MM/DD/YYYY)	Approved and Recorded in	Signed by	Signature authorised by Notified Body No. 0041
Manchester, UK	07/11/2011	UK	Patrick Hennessey	
Code d'enregistrement / Registration code: 2011/200.11,1844/PUK				

This certificate is subject to the terms of Bureau Veritas General Conditions of Service attached to the agreement signed by the applicant.

**THE NATIONAL BOARD  
OF  
BOILER & PRESSURE VESSEL INSPECTORS**

*Certificate of Authorization  
to Register*



*This is to certify that*

**INTEGRATED FLOW SOLUTIONS  
6461 REYNOLDS RD.  
TYLER, TX 75708**

*is authorized to apply the “NB” mark and register  
boilers, pressure vessels or other pressure retaining  
items with the National Board.*

*The scope of Authorization is limited to items  
manufactured in accordance with:*

*ASME Designator(s): U, S*

**ISSUE DATE: February 6, 2015**

*This Certificate of Authorization to Register will remain  
in effect as long as the manufacturing organization holds  
a valid Certificate of Authorization issued by the  
American Society of Mechanical Engineers.*

Executive Director

A handwritten signature in black ink, appearing to read 'D. ...', positioned above the title 'Executive Director'.



**THE NATIONAL BOARD  
OF  
BOILER & PRESSURE VESSEL INSPECTORS**

*Certificate of Authorization*



*This is to certify that*

**Integrated Flow Solutions  
6461 Reynolds Rd.  
Tyler, Texas 75708  
United States**

**Acceptable Abbreviation: IFS**

*is authorized to use the R Symbol in accordance with the provisions of the National Board Inspection Code and NB-415, Accreditation of "R" Repair Organizations.*

All activities within the scope of this Authorization shall be controlled by the above location.

The scope of this Authorization is limited to:

Metallic  
Repairs and Alterations  
At  
Shop and Field Locations

Certification Number: 5531

Issue Date: January 18, 2018

Expiration Date: February 24, 2021

Executive Director





# CERTIFICATE OF AUTHORIZATION

The named company is authorized by the American Society of Mechanical Engineers (ASME) for the scope of activity shown below in accordance with the applicable rules of the ASME Boiler and Pressure Vessel Code. The use of the certification mark and the authority granted by this Certificate of Authorization are subject to the provisions of the agreement set forth in the application. Any construction stamped with this certification mark shall have been built strictly in accordance with the provisions of the ASME Boiler and Pressure Vessel Code.

COMPANY:

**Integrated Flow Solutions  
6461 Reynolds Rd.  
Tyler, Texas 75708**

SCOPE:

**Manufacture of pressure vessels at the above location and field sites controlled by the above location (This authorization does not cover impregnated graphite)**

AUTHORIZED: **January 23, 2018**

EXPIRES: **February 24, 2021**

CERTIFICATE NUMBER: **31,698**

A handwritten signature in black ink, appearing to read 'Richard R. Stevenson'.

Board Chair, Conformity Assessment

A handwritten signature in black ink, appearing to read 'Joseph A. ...'.

Managing Director, Conformity Assessment





# CERTIFICATE OF AUTHORIZATION

The named company is authorized by the American Society of Mechanical Engineers (ASME) for the scope of activity shown below in accordance with the applicable rules of the ASME Boiler and Pressure Vessel Code. The use of the certification mark and the authority granted by this Certificate of Authorization are subject to the provisions of the agreement set forth in the application. Any construction stamped with this certification mark shall have been built strictly in accordance with the provisions of the ASME Boiler and Pressure Vessel Code.

COMPANY:

**Integrated Flow Solutions  
6461 Reynolds Rd.  
Tyler, Texas 75708**

SCOPE:

**Manufacture and assembly of power boilers at the above location and field sites controlled by the above location**

AUTHORIZED: **January 23, 2018**  
EXPIRES: **February 24, 2021**  
CERTIFICATE NUMBER: **42,674**

  
Board Chair, Conformity Assessment

  
Managing Director, Conformity Assessment







# LETTER OF VALIDATION

The CWB acknowledges that

## **Integrated Flow Solutions, LLC**

6461 Reynolds Road

Tyler, TX, 75708, USA

is certified to CSA Standard **W47.1**

**“Certification of Companies for Fusion Welding of Steel”**

**In Division 2**

for the period **07/26/2018** to **08/25/2019**

**Company Code: INTFL1**

**Scope:** Miscellaneous structural steel fabrication.

Reason for Issue: Renewal

Issue Date: 07/26/2018

*For the latest CWB certification Documents & Forms and Certification Terms & Conditions, please visit: [www.cwbgroup.org](http://www.cwbgroup.org)*

Registrar



Accredited  
CB-PS  
(Certification Body - Product/Services)

8260 Parkhill Drive, Milton, Ontario L9T 5V7  
1-800-844-6790 | Int: 905-542-1312 | Fax: 905-542-1318  
Email: [info@cwbgroup.org](mailto:info@cwbgroup.org) | Web: [www.cwbgroup.org](http://www.cwbgroup.org)



# CANADIAN WELDING BUREAU

The CWB acknowledges that

## **Integrated Flow Solutions, LLC**

6461 Reynolds Road , Tyler, TX 75708 USA

**is Certified to CSA Standard W47.1**

---

Certification of Companies for Fusion Welding of Steel

**In the DIVISION 2**

**INITIAL CERTIFICATION DATE: April 9, 2015**

**Scope: Miscellaneous structural steel fabrication.**

*Registrar & Manager Q.A.*

*Authorized Signing Officer*

---

Certification is validated yearly via a "Letter of Validation", a copy of which is available from the company



Accredited  
CB-PS  
(Certification Body-Product/Services)

The Canadian Welding Bureau is accredited by the Standards Council of Canada

The product certification system operated by the Canadian Welding Bureau most closely resembles that described by ISO/IEC Guide 67, Conformity assessment — Fundamentals of product certification, System 6.

# Certificate of Compliance

**Certificate:** 1621441

**Master Contract:** 228216

**Project:** 1621441

**Date Issued:** 2005/02/21

**Issued to:** **Integrated Flow Solutions**  
**6461 Reynolds Road**  
**Tyler, TX 75708**  
**USA**  
**Attention: Ryan Skender**

*The products listed below are eligible to bear the CSA Mark shown*



**Issued by:** James Rusnak

**Authorized by:** Janusz Pankowski, Manager of  
Certification Services

*Janusz Pankowski*

**PRODUCTS**

**CLASS 3211 09** - INDUSTRIAL CONTROL EQUIPMENT - Special (Custom) Industrial  
Control Assemblies

Special control assemblies, enclosed 600V ac max., 1 or 3 ph, 60Hz, 500A max , 200 hp, full voltage starter or variable speed drives, consisting of CSA components such as enclosures Type 1, 3, 3R, 4, 4X or 12, fuses, switches, circuit breakers, starters, contactors, transformers, control relays, plcs, timers and auxiliary devices.

Note: This Certification does not cover Control Panels for Cranes and Hoists, Refrigeration Compressor controllers, Heating Equipment, Fuel Burning Equipment, Capacitor Banks, Automatic Transfer Switches, Elevator Equipment, Motor Control Centers, Equipment with Service Entrance Compartment or for Equipment to be installed in Hazardous Locations.



**Certificate:** 1621441

**Master Contract:** 228216

**Project:** 1621441

**Date Issued:** 2005/02/21

---

**APPLICABLE REQUIREMENTS**

CSACAN/CSA-C22.2 No. 14-95 - Industrial Control Equipment

**SGS**

January 30, 2004

To: Integrated Flow Solutions  
9800 NW Freeway, Suite 205  
Houston, TX 77092

Attn: Bill Marsh

Re: ExxonMobil Sakhalin-I Project. Russian certification issue.

Gentlemen:

Thank you for giving me the opportunity to meet with you and provide for your understanding of the Russian mandatory industrial certification services SGS offers.

Please keep in mind that SGS is the only US firm officially accredited by Gosstandart (GOST-R) of the Russian Federation. SGS can supply Technical Passports, Gosgortekhnadzor (GGTN) Permits of Use, Gosenergonadzor (GEN) Explosion-Proof Approval Certificates, GOST-R Certificates of Conformity, and other mandatory Russian certification documents to legitimize you products to be delivered to Russia, depending upon your specific requirements and certification needs. Having gained an overwhelming experience in the field of foreign mandatory industrial certification (since 1993), SGS' experts and specialists will be happy to work with IFS to assist in identifying the correct Russian certification requirements/scope and execute all applicable certification procedures.

After reviewing IFS's products and standard project documentation, I feel quite confident that SGS is fully capable of rendering all necessary certification services and supplying all necessary Russian certification documents to IFS, with no negative impact on IFS's competitive position worldwide.

I look forward to working with IFS on the Sakhalin-I Project, as well as other certification projects developed in both Russia and other CIS countries.

Kind Regards,



Eugene Nizhniy  
Product Certification Manager

Subscriber No:	176079
Employee No:	16516
(For Internal UL Use Only)	

**UNDERWRITERS LABORATORIES INC. ®**  
**UL SERVICES AGREEMENT**

TO: UNDERWRITERS LABORATORIES INC.\*

Return to Address Indicated	{	<input type="checkbox"/> 333 Pfingsten Rd., Northbrook, IL 60062-2096	<input checked="" type="checkbox"/> 12 Laboratory Dr., P.O. Box 13995
		<input type="checkbox"/> 1285 Walt Whitman Rd., Melville, L.I. NY 11747-3081	<input checked="" type="checkbox"/> Research Triangle Park, NC 27709-3995
		<input type="checkbox"/> 2600 N. W. Lake Road, Camas, WA 98607-8542	
		<input type="checkbox"/> 1655 Scott Blvd., Santa Clara, CA 95050-4169	

THIS AGREEMENT is made at Northbrook, Illinois, as of January 31, 2003, by and between Underwriters Laboratories Inc. ("UL"), a not-for-profit Delaware corporation, 333 Pfingsten Road, Northbrook, Illinois 60062 and INTEGRATED FLOW SOLUTIONS

TYLER TX  
*(Company Name, City and State [or Country if not in U.S.A.]*

(hereinafter sometimes referred to as "Subscriber").

Under this Agreement, Subscriber enters into a relationship with UL as: (a) an "Applicant" who submits devices, equipment, materials or systems ("products") to UL for investigation to assess the product's conformity with UL's Requirements and the eligibility of those products for UL's Listing, Classification, Recognition, Verification, Follow-Up Service and/or other Service ("UL Service"); (b) a "Manufacturer" who manufactures or assembles products covered by UL Service; and/or (c) a "Listee" whose name is listed in UL's published records in connection with products covered by UL Service. "Subscriber" shall refer to a party acting as an Applicant, Manufacturer or Listee unless otherwise indicated. UL will investigate submitted products and, if eligible, in UL's sole opinion, permit the use of the UL's registered Certification Marks or other markings ("Marks") under the following terms and conditions:

- A. **Product Investigation Fees.** UL will establish a fee for each product investigation (including engineering, technical and support personnel charges). The fee covers one examination and set of tests that UL determines are appropriate for the product (not including testing of additional samples, separate investigation of components of a product, or reimbursable expenses), and the preparation of a report. The fee shall not be exceeded without written authorization.
- B. **Follow-Up Service Fees.** UL's Follow-Up Service is an integral part of UL Service and includes, without limitation, inspection of facilities where products covered by UL Service are manufactured or assembled, and additional testing to determine whether manufactured products are eligible for UL Service. UL will bill Subscriber for Follow-Up Service at UL's current rates, which may change from time to time as determined by UL, in its sole discretion. Follow-Up Service charges may vary depending upon the nature and extent of the necessary inspection, testing and evaluation, including any extra costs resulting from the failure of a product to conform to UL's Requirements or insufficient Manufacturer quality control procedures.
- C. **Expenses.** Reimbursable expenses associated with a product investigation may include, without limitation: travel expenses; carrier, communications and special equipment charges; materials, energy and fuel; services of outside contractors or facilities; charges for photographs, drawings, reproductions and printing; and charges for preparation of extra copies of UL reports and other documents.
- D. **All fees and reimbursable expenses associated with each product investigation shall be paid regardless of whether the product investigation results in any product being eligible for UL Service.** UL may require a deposit (to be credited against the total charges) before UL begins a product investigation. UL also reserves the right to share an Applicant's credit history and information with its affiliates. UL reserves the right to refuse to investigate or cancel the investigation of any product submitted at any time. All costs and expenses UL has incurred up to the date the product investigation is terminated shall be paid.
- E. **Applicant shall be responsible for payment of all services and expenses in connection with products covered by UL Service.** UL may render invoices for all UL Service on a monthly basis. All charges shall be paid without set off upon presentation of invoices by UL and shall be considered in default if Subscriber fails to pay such charges within thirty (30) days after presentation. UL may charge interest at the rate of 1.5% per month (18% per year), or the maximum legal rate, from the due date until paid. If charges are not paid when due, UL may deny or withdraw UL Service for any of Subscriber's products.

**WE AGREE TO THE TERMS AND CONDITIONS ON ALL FOUR PAGES OF THIS AGREEMENT AND WARRANT THAT NO ALTERATIONS OF ITS TEXT HAVE BEEN MADE WITHOUT UL'S PRIOR WRITTEN CONSENT. THE UNDERSIGNED REPRESENTS AND WARRANTS THAT S/HE IS AUTHORIZED TO EXECUTE THIS AGREEMENT ON BEHALF OF SUBSCRIBER.**

UNDERWRITERS LABORATORIES INC.  
  
By: JANE L. COEN  
CORPORATE SECRETARY  
*(Typed Name and Title)*

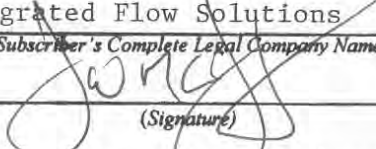
Integrated Flow Solutions  
*(Subscriber's Complete Legal Company Name)*  
By:   
*(Signature)*  
John McIntyre / General Manager  
*(Typed Name and Title)*

1.0 Establishment of UL Service.

1.1 If UL determines that a product is eligible for UL Service, UL will prepare and lend a Follow-Up Service Procedure for the product (the "Procedure") to the Manufacturer(s) to be issued only after establishment of UL Service in the form and manner UL determines. The Procedure contains provisions and conditions identifying and defining the product, the UL Service and the conditions for use of the Marks in connection with the product, and the facilities at which UL Marks are to be applied. The parties agree that any Procedure prepared by UL for a product is hereby made a part of and incorporated by reference into this Agreement. In particular, the provisions and conditions of the Procedure shall govern the use of the Marks.

1.2 Before UL establishes UL Service for a product, the Applicant will provide UL with the intended Listee's company name and address (if different than the Applicant) and the name of the Manufacturer(s) and address of the factory(ies) at which the product is manufactured or assembled. When UL Service is established, the Listee's name and the identification of the covered products will appear in UL's published records. Listee authorizes UL to publish its name and other information regarding the product in UL's published records. No UL Service will be established or maintained unless all appropriate Applicants, Listees and Manufacturers have executed and continue to comply with an agreement designated by UL.

1.3 Subscriber acknowledges that the Manufacturer(s) of the product must demonstrate to UL's satisfaction that the Manufacturer(s) will produce the product in accordance with this Agreement including, without limitation, the Procedure. UL also reserves the right to conduct an "Initial Production Inspection" (IPI) to determine whether the manufactured products conform to UL's requirements. The Manufacturer(s) shall establish and maintain a program of production, inspection and tests to assure that products bearing the Marks comply with UL's Requirements. UL Service shall be terminated for any product that, for any reason, is no longer eligible for UL Service.

1.4 Subscriber agrees that if a revision in UL's Requirements is adopted or the requirements are withdrawn during the term of the Agreement, UL shall determine the date by which use of the Mark under the Requirements shall terminate and shall notify the Subscriber of such date. Subscriber agrees to comply with any such notice. If the Requirements are revised, the continued coverage of the product and the rights of the Subscriber to use the Mark beyond the specified date shall be contingent upon a revised product being submitted to UL, found to comply with the applicable requirements, and appropriate revisions made in the Procedure. If the product is found not to comply with the revised requirements, or if the requirements are withdrawn, the coverage of the product shall be terminated on the specified date and the right to use the Mark will cease on that date. Where examination and/or testing of the product is necessary to determine its compliance with new or revised requirements, the cost of such determination shall be charged to the Applicant on the same basis as a new product submittal.

2.0 Conduct of Follow-Up Service.

2.1 Subscriber agrees that UL representatives will make periodic examinations or tests of the products at factories where covered products are manufactured. UL may, from time to time, select samples at the factory, place of sale or elsewhere for examination or testing to determine compliance with UL's Requirements. UL's Follow-Up Service, and any sampling, inspections or tests conducted by UL as part of the Follow-Up Service, is designed to serve only as a check on the means the Manufacturer(s) use to determine compliance of the products with UL's Requirements and does not relieve Subscriber of any responsibility for its products.

2.2 UL's representatives shall have free, unannounced, immediate, safe and secure access to factories or storage facilities where the products or any components are fabricated, processed, finished, stored or located, at all times during business hours or when the factory or storage facilities are in operation in order for UL's representatives to perform their duties. Subscriber agrees to provide UL's representatives with all safety and other protections required by law for its own employees including, without limitation, all Occupational Health and Safety Administration rules and regulations. The right of UL's representatives to obtain free access to a factory or storage facility shall not be conditioned upon the execution by UL or the representative of any agreement, waiver, or release which in any way purports to affect the legal rights or obligations of UL or the representative. However, UL shall direct its representatives to exercise due care to comply with any plant safety regulations generally applicable to personnel at the factory or storage facility.

2.3 The Manufacturer(s) shall make all Marks and the means of applying such Marks available for inspection by UL's representatives at all reasonable times. If UL's examination or tests disclose features which, in the sole opinion of UL's representative, are not in compliance with UL's Requirements, the Manufacturer(s) will either correct such items or remove the Marks from all products designated by the representative. If the Manufacturer(s) disagree with UL's representative regarding whether a product is eligible to use the Marks, the Manufacturer(s) may hold the product at the factory or storage facility pending an appeal to and a decision by UL.

3.0 Subscriber's Acknowledgements.

3.1 Subscriber represents and warrants that all the information and data provided to UL by Subscriber or on its behalf is complete and accurate and that UL may rely upon such information when testing, investigating and establishing a UL Service for Subscriber's product. In the event that any UL Service is established, Subscriber agrees that it will comply with the applicable UL Requirements at all times including (a) the description, specifications, and Requirements contained in the Procedure; (b) the published Standard(s), if any, applicable from time to time to the covered product; and (c) the performance Requirements applied as a condition of UL Service.

3.2 Subscriber recognizes that each product investigation is unique and that the timing of each investigation will vary depending upon the particular investigation and the findings. Subscriber agrees that UL, its trustees, members, officers, employees, subcontractors, and agents shall have no obligation or liability for any damages, including consequential damages, or for specific performance arising from UL's performance, non-performance, or delay in performance under this Agreement.

3.3 Subscriber agrees that UL shall not be responsible for lost, damaged or destroyed samples or for injuries or damages of any nature caused by any sample. UL will return tested samples to Subscriber (insured for a nominal value) unless they are completely destroyed during UL's investigation or Subscriber instructs UL otherwise in writing.

3.4 Subscriber agrees that UL does not assume or undertake to discharge any responsibility of Subscriber to any other party. Subscriber recognizes that UL's opinions and findings represent its judgment given with due consideration to the necessary limitations of practical operation in accordance with UL's objects and purposes. Subscriber agrees that UL does not warrant or guarantee that its opinions or findings will be recognized or accepted.

3.5 Subscriber recognizes that UL testing may be inherently hazardous. UL does not assume or accept responsibility or liability for any personal injury, death or property damage to Subscriber's personnel or property in connection with any tests performed at any location by any persons, including without limitation, personnel of UL, Subscriber or any third party, unless due to UL's sole negligence.

3.6 Subscriber agrees to indemnify, defend and hold UL, its trustees, members, officers, employees, agents and subcontractors, harmless against any claims, suits, losses, judgments, costs, fines, liabilities or expenses, including attorneys' fees of counsel of UL's choosing, arising from any misuse by the Subscriber of the Marks or arising from any violation by the Subscriber of the terms and conditions of this Agreement.

3.7 Subscriber acknowledges its willingness to support UL's public safety mission and that UL, as the certifier of Subscriber's products, is entitled to receive information developed or collected by Subscriber regarding the field performance of UL certified products. Accordingly, Subscriber will make available to UL for inspection and copying, all documents, test results, and other information with respect to a product (i) that is subject to Section 15(b) of the Consumer Product Safety Act, 15 U.S.C. § 2064(b); (ii) that fails to meet a consumer product safety standard or; (iii) that could create a substantial hazard to users. With respect to documents provided by Subscriber to the U.S. Consumer Product Safety Commission or any similar federal, state or local agency, Subscriber authorizes that agency to make those documents available to UL for inspection and copying. Subscriber further agrees that it will cooperate with and assist UL in connection with its investigation of any affected products and undertake such corrective action, including recall, where, in UL's sole opinion, such action is in the best interests of public safety.

4.0 Confidentiality. UL agrees not to voluntarily disclose secret information obtained in confidence from Subscriber to third parties without Subscriber's prior written authorization unless the information is already known to UL, publicly available, subsequently acquired from other sources, or disclosure is required by law. Subscriber agrees that UL, as an independent not-for-profit organization testing for public safety, will from time to time notify the public concerning products then or previously marketed that UL's investigations reveal present, in UL's sole opinion, substantial hazards.

4.1 Subscriber hereby authorizes UL to transmit unencrypted confidential information and other information through the Internet or a public network to e-mail addresses or other locations provided by Subscriber. Subscriber acknowledges that UL cannot guarantee the privacy and confidentiality of such transmissions. Subscriber agrees that UL's transmission of confidential information via the Internet or other public network shall not be a breach of any confidentiality obligation under this Agreement and that UL shall not be liable for any damages resulting from such transmissions.

5.0 The UL Marks. Subscriber acknowledges that UL is the owner of registered Certification Marks. Subscriber assumes full and complete responsibility for its use of the Marks. Subscriber agrees that it will, through proper inspection or otherwise, determine that products bearing the Marks have been made in compliance with UL's Requirements. Subscriber agrees that its use of the Marks constitutes its declaration that the products are covered by UL Service and have been made in compliance with UL's Requirements.

5.1 Unless otherwise authorized by UL, the Marks shall be in the form of separable, legible labels not readily transferable from one product to another. Orders for separable labels shall be processed through UL and obtained only from a printer or manufacturer of Marks authorized by UL.

5.2 Notwithstanding that the manufacturing cost of labels or other means of applying the Marks are not paid by UL, it is agreed that title to and control of labels, markers, or other means of marking shall be vested in UL until such time as the Marks are properly applied to the covered product in accordance with this Agreement. UL's representatives shall have the right, on demand, to acquire possession of any or all unused labels, markers, or other means of applying the Marks when, in the opinion of UL's representative, that action is warranted.

5.3 Subscriber agrees that the manufacture, sale, delivery, shipment, distribution or promotion of any product utilizing a Mark or description referring to UL would mislead the public if such product is not covered by UL Service, does not comply with UL's Requirements or if the Marks are used in any other way than as provided in this Agreement and the applicable Procedure. Subscriber agrees that such a breach of this Agreement could not adequately be compensated for in money damages. Subscriber agrees that a temporary injunction may be issued at UL's request prohibiting Subscriber from: (i) using the Marks or referring to UL in any manner; (ii) selling, offering for sale, delivering or distributing any products bearing the Marks or referring to UL in any way; or (iii) any other appropriate relief. The parties agree that such a temporary injunction shall not affect UL's right to compensatory or punitive damages for misuse of the Marks or UL's name, abbreviations or symbols and shall be in addition to, and not in lieu of, any other rights and remedies provided by this Agreement or law.

5.4 Recognized Components are not eligible to bear the registered UL Listing Mark or Classification Marking. Manufacturers of components produced under UL's Recognition Service are only authorized to use the registered Recognized Component Mark or other specified Markings to identify the covered product.



6.0 References to UL. Subscriber acknowledges that UL owns several Marks including, without limitation, "Underwriters Laboratories Inc.," "UL" and the UL Recognized Component Mark. Subscriber shall not use Underwriters Laboratories Inc.'s name, or any abbreviation or symbol or Mark, thereof, on or in connection with products, containers or packaging, unless and until expressly authorized by the Procedure and then only in the form or manner specified in the Procedure, e.g., Subscriber may not refer to a product submitted for UL Service as "UL pending." Subscriber agrees that UL may notify vendors, authorities, potential users and others of any improper or unauthorized use of the Marks or reference to UL when, in UL's sole opinion, necessary for public safety or the protection of the Marks.

6.1 Use of UL Name and Marks in Advertising and Promotional Materials. UL will permit the use of appropriate references to Underwriters Laboratories Inc., such as "Listed by Underwriters Laboratories Inc.," "Underwriters Laboratories Inc. Listed," "UL Listed," "Listed by U. L., Inc.," "Recognized by ...," "UL Recognized ...," or the form or text (wording) specified in the Procedure in promotional or advertising material, in any form including without limitation print or electronic media, solely in connection with covered products that bear the Marks, provided that in UL's sole opinion the promotional or advertising material is not in conflict with the findings and coverages of UL and that the reference to Underwriters Laboratories Inc. in no way tends to create a misleading impression as to the nature of UL's findings, its coverages and Service. Except for the Mark that is prescribed for use in a specific relevant Procedure, no other UL Marks may be used in the advertising and promotional material supplied with covered product. In those instances where a Marking is used, any text which is required by the Procedure shall be set forth in full.

7.0 Termination. This Agreement will continue in effect until terminated as set forth below.

7.1 Either party may terminate this Agreement, with or without cause, at any time upon thirty (30) days prior written notice to the other party. Any termination notice shall specify the proposed termination date. The parties agree that any notice of termination shall be sufficient if sent by registered or certified mail addressed to either UL (with copies to UL's Corporate Secretary and General Counsel) or Subscriber at its last known address. The notice period shall begin on the date a party deposits the notice in the mail, properly addressed and postage prepaid.

7.2 UL may immediately terminate or suspend this Agreement at any time upon written notice to Subscriber if, among other things, Subscriber: (i) becomes insolvent or makes a general assignment for the benefit of creditors or a petition under the Bankruptcy Act is filed with respect to Subscriber; (ii) becomes involved in legal proceedings that, in UL's sole discretion, interfere with performance of this Agreement; or (iii) defaults in any of its obligations under this Agreement. Termination of this Agreement will not affect the parties' obligations existing as of the date of termination, shall not relieve the Subscriber of its indemnity obligations, or excuse Subscriber from paying any charges owing to UL. Upon termination, with or without cause, of any rights or authority conferred by this Agreement, UL shall (a) discontinue UL Service on any affected products and/or (b) have the right to acquire possession of any Procedure or any unused Marks which, in its sole opinion, were issued for use in connection with any product that is the subject of the termination. Subscriber shall discontinue the use of the Marks on or in connection with any product that is the subject of such termination. Subscriber also shall discontinue any reference to UL in connection with any product which is the subject of such termination in promotion, advertising or otherwise. The foregoing does not in any way limit the actions that UL may take in the event of the termination of any rights or authority conferred by this Agreement.

8.0 Waiver. Any failure by a party to insist upon the performance of any provision of this Agreement shall not constitute a waiver of any rights under the Agreement or future performance of that provision.

9.0 No Third Party Beneficiaries. No provisions of this Agreement shall in any way inure to the benefit of any third party, including the public at large. The parties intend that no third party shall have any rights or cause of action under this Agreement.

10.0 Governing Law. This Agreement shall be governed by the laws of the State of Illinois, USA without reference to its choice of law principles. Any action related to the Agreement shall be filed in the federal or state court having jurisdiction in Cook County, Illinois, USA. The parties consent to the exercise of personal jurisdiction of that court and shall bear any costs, legal fees and expenses incurred in transferring actions filed elsewhere.

11.0 Subcontracting. The Subscriber agrees that UL may, in its sole discretion, subcontract testing or other services. All subcontractors shall meet UL's current qualification requirements and comply with UL's requirements for confidentiality, conflicts of interest and ethical standards.

12.0 No Assignment. Subscriber may not assign any of its rights or obligations under this Agreement to any other person without UL's written authorization.

13.0 Entirety of the Agreement. This constitutes the entire and complete agreement between the parties and supersedes any other communications, representations or agreements with respect to its subject matter. This Agreement may only be modified by a writing duly executed by authorized persons for both parties. No preprinted additional or different terms or conditions on either party's purchase orders, invoices, sales or marketing materials or other business documents shall apply to any investigation or transaction under this Agreement. Subscriber represents and warrants that it is authorized to execute this Agreement; that its representative has read the Agreement and understands its terms; that each party has had access to legal counsel; and that each party intends to be legally bound by this Agreement.



# IFS Customers

