

AFCU Series Ammonia Flow Control Unit

Integrated Flow Solutions AFCU Series Ammonia Flow Control Units are designed to control the flow of ammonia from the Ammonia Storage / Forwarding System into an air or flue gas stream. The air is typically pressurized and heated with an electric process heater or low pressure steam. The hot flue gas is available from the gas turbine exhaust. The hot air or flue gas vaporizes the ammonia prior to injection into the Ammonia Injection Grid (AIG).

Industries



Applications – See industry tab

Benefits:

- Single Source Accountability
- Pre-Packaged Modular Design Costs Less than component based site built which reduces overall project cost
- Minimizes field erection time – shorter overall project delivery schedule
- Complete system function testing prior to shipment
- 24/7 Customer service

Industry Standards

- Piping designed to ANSI B31.1/ANSI B31.3
- Pipe fabrication to ASME Section IX
- Structural Steel Assembly Designed to AWS D1.1
- Complete system designed to API RP 550

Standard Features:

- Heavy Duty Single or Multistage Centrifugal Air Blowers - Arrangement 4, 7, & 8
- Integraheat™ Electric Process Air Heating with full Thyristor Power Controls, Motor Interlock and Redundant Safety Shutdown System
- Locally mounted PLC based control system per NEC & NFPA
- Vaporization using Co-Current Mixing or Counter Flow Contact Technology
- Complete factory function test

Process Parameters:

- Vaporized Ammonia – up to 4,000 #/hr
- Exhaust temperatures – up to 800F
- Discharge pressures – up to 6 psig



Utility Requirements (Cold-AFCU):

- Heat Source: Integraheat™ Electric Process Air Heater
 - Power Requirement: 1KW - 1500KW/3 phase/60 hertz
- or
- Heat Source: Steam Heat Exchanger
 - Total Duty – up to 12,500 MM BTU/HR
- Blower Motors – up to 300 hp/3 phase/460 volt
- Instrument Air

Utility Requirements (Hot-AFCU):

- Heat Source: Hot Flue Gas
- Blower Motors – up to 300 hp/3 phase/460 volt
- Instrument Air

Optional Features:

- Complete Factory Performance Test
- UL or CSA Listed Control Heater & Control Panel Assembly
- Class 1, Div 2 Hazardous locations
- Compliance with Plant / Engineering Specifications

Additional Services:

- “Aspen Plus” Process Simulation Software used to guarantee process conditions
- Installation / Training / Start – Up Supervision
- Extended warranty
- Nationwide Service Network

Ammonia Flow Control Unit

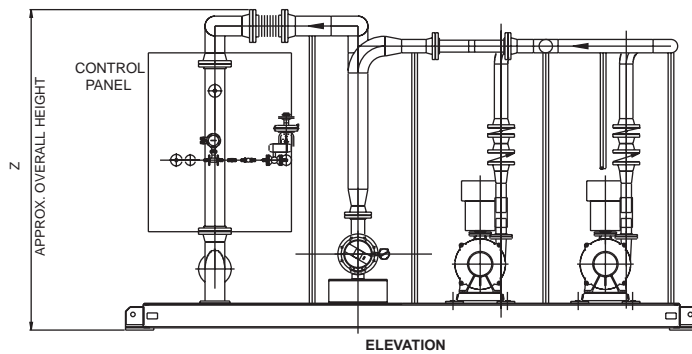
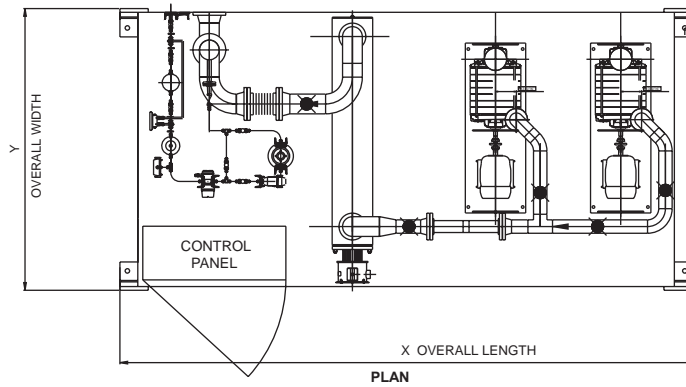
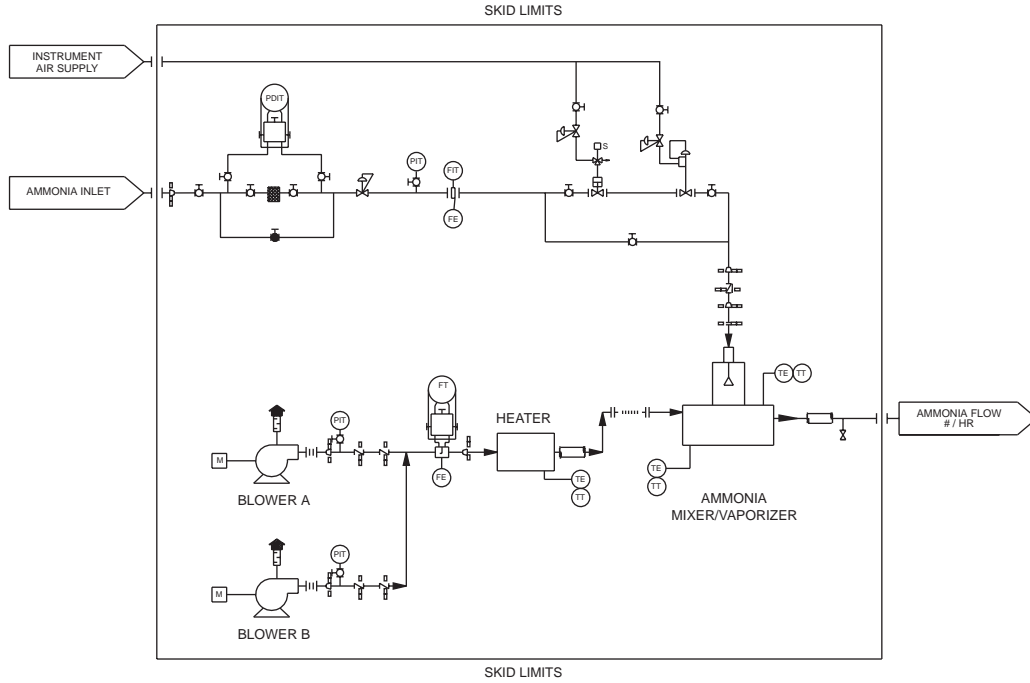

AMMONIA FLOW - #/HR	LENGTH - X	WIDTH - Y	HEIGHT - Z	WEIGHT - LBS.
100	15'	8'	10'	10,000
500	22'	10'	10'	15,000
900	30'	12'	10'	20,000