

# ANAN Series Anhydrous Ammonia Rail or Tank Car Unloading Package

Integrated Flow Solutions ANAM Series Anhydrous Ammonia Rail or Tank Car Unloading Packages are designed to unload Anhydrous Ammonia from railroad cars and truck transports into a modular Storage/Forwarding System which includes a storage tank, vaporizer, instrumentation, & controls. The complete system is designed to minimize field assembly.

## Industries



*Applications – See industry tab*

## Benefits:

- Single Source Accountability
- Pre-Packaged Modular Design Costs Less than component based site built which reduces overall project cost
- Minimizes field erection time – shorter overall project delivery schedule
- Complete system function testing prior to shipment
- 24/7 Customer service

## Industry Standards

- Vessels code stamped ASME Section VIII & National Board Registered
- Piping designed to ANSI B31.1/ANSI B31.3
- Pipe fabrication to ASME Section IX
- Structural Steel Assembly Designed to AWS D1.1
- Complete system designed to API RP 550 & K61.1

## Standard Features:

- IntegraSafe Unloading Station
  - Local indication of:
    - Tank level
    - Tank pressure
    - Flow indication
  - Local manual/automated valve operation
- Storage/Forwarding System
  - Vessel storage up to 30,000 gallons
  - Single & Double wall carbon steel vessels
  - Integraheat™ Electric Vaporizer ASME Code Stamped (Locally Mounted)
  - Full Thyristor (SCR) Control Panel with Redundant Safety Shutdown System (Locally Mounted) per NEC & NFPA
- Complete factory function test

## Optional Features:

- UL or CSA Listed Heater and Control Panel Assembly per NEC & NFPA
- Class 1, Div 2 Hazardous Locations
- Compliance with Plant/Engineering Specifications

## Additional Services:

- “Aspen Plus” Process Simulation Software used to guarantee process conditions
- Installation / Training / Start – Up Supervision
- Extended warranty
- Nationwide Service Network

# Anhydrous Ammonia Unloading Station & Storage Vaporizer System

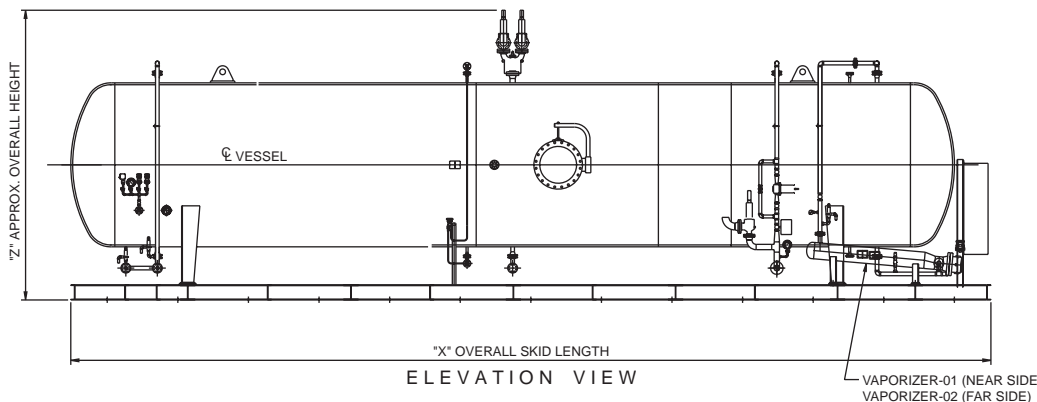
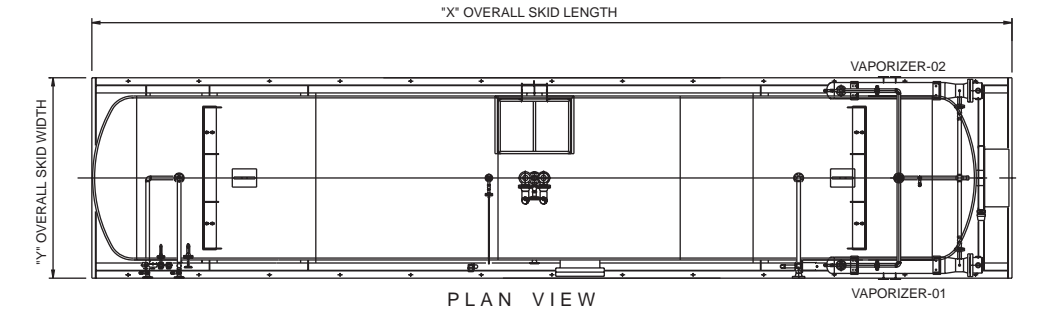
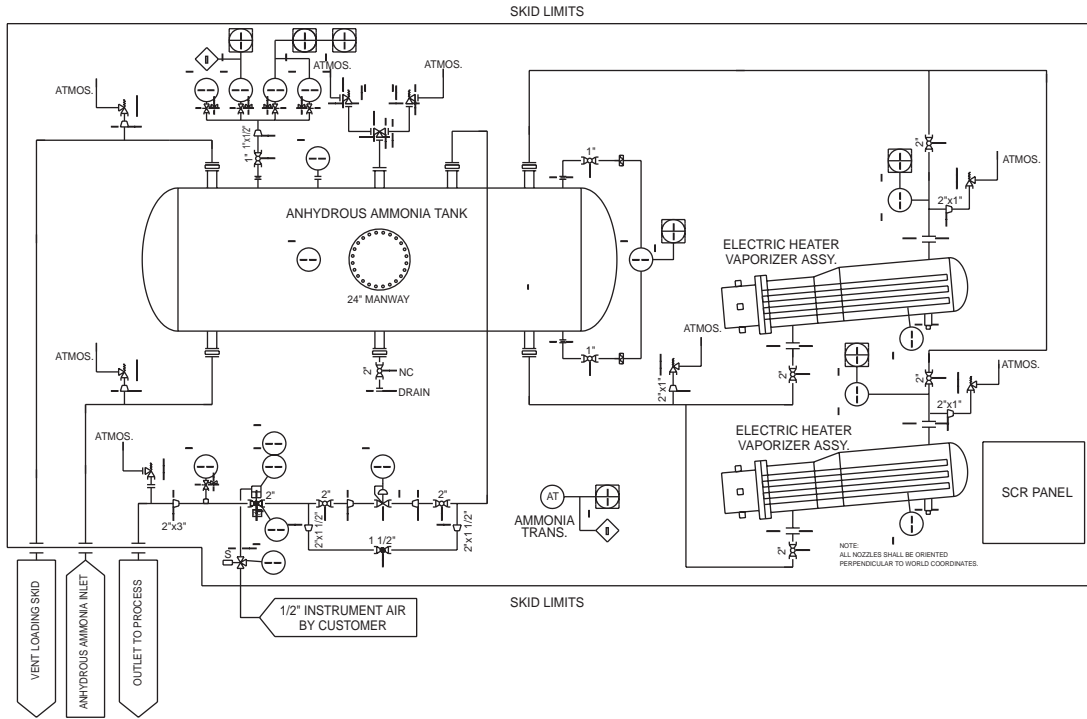

WORKING VOLUME - GALLONS	LENGTH - X	WIDTH - Y	HEIGHT - Z	WEIGHT - LBS.
6,000	20'	11'	14'	15,000
10,000	34'	11'	14'	25,000
14,000	50'	11'	14'	35,000
18,000	60'	11'	14'	45,000
22,000	75'	12'	16'	55,000