

Packaged Pumping System with Building (PPSB)

Integrated Flow Solution's Packaged Pumping System with Building is designed to minimize on site installation costs by including the complete pumping system, electrical switchgear, instrumentation, and insulated building enclosure in one transportable module. PPSB Series are used for water injection, effluent transfer, pipeline, chemical injection, and firewater systems. The complete system includes pumps, electric motors, suction/discharge piping, valving, instrumentation, controls, & switchgear.



Industries



POWER



OIL & GAS



GENERAL



EMISSIONS

Benefits

- Single Source Accountability
- Pre-Packaged Modular Design Costs Less than component based site built which reduces overall project cost
- Minimizes field erection time – shorter overall project delivery schedule
- Complete system function testing prior to shipment
- 24/7 Customer service (1-800-859-8724)

Industry Standards

- Vessels code stamped ASME Section VIII & National Board Registered
- Piping designed to ANSI B31.1/ANSI B31.3
- Pipe fabrication to ASME Section IX
- Structural Steel Assembly Designed to AWS D1.1
- Structural building panels designed to the latest edition of AISC "Specifications for the Design, Fabrication, and Erection of Structural Steel Buildings"
- Building loads designed in accordance with the Metal Building Manufacturers Association publication, "Recommended Design Practice Manual"

Standard Features

- Pump Types
 - API 674 Horizontal multiplex plunger
 - ANSI B73.1 or ANSI B73.2 Single stage centrifugal
 - API 610 Single or multistage centrifugal
 - API 675 Metering
- Electric motor or engine (gas or diesel) drive
- Full pump/motor instrumentation including vibration, temperature, flow, & pressure monitoring.
- Rigid structural steel base with curbed perimeter & drain to minimize environmental impact
- Hydrotesting of all piping
- High quality industrial coating system

Optional Features

- Simplex, Duplex, and Triplex pump configurations
- All NEMA or IEC rated enclosures and components for Class 1, Div. 1 or Div. 2 electrical areas
- Human Operator Interface
- Microprocessor controller with Integraflow™ control software to monitor critical functions & provide complete system control
- Complete string test of package
- Building panels designed with Arctic insulation for severe weather installations

Additional Services

- Nationwide Service Network
- Installation & Supervision
- Turn-Key Projects
- Equipment leasing Program
- Extended Equipment Warranty

Packaged Pumping System with Building

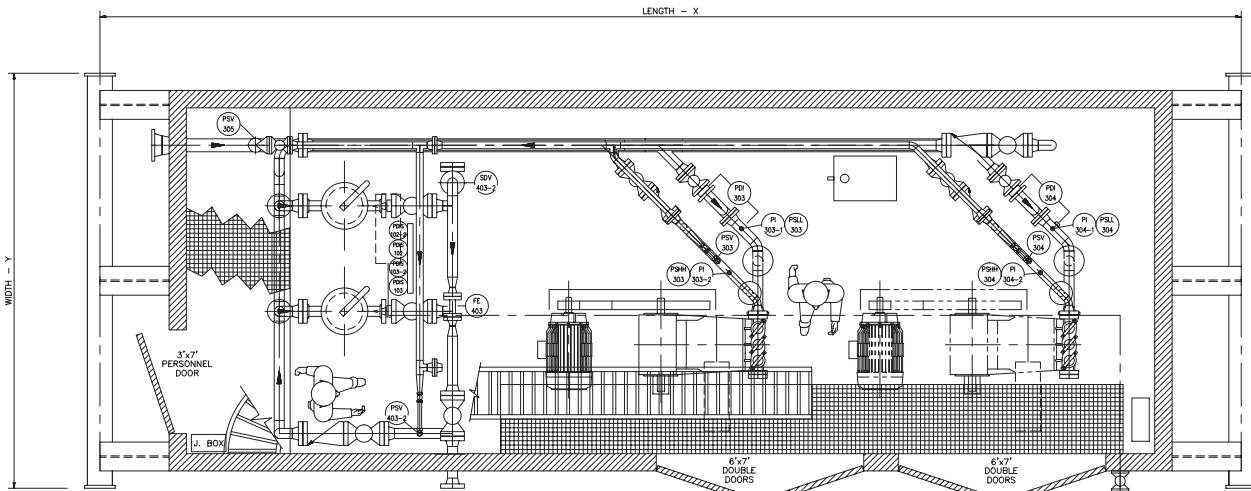
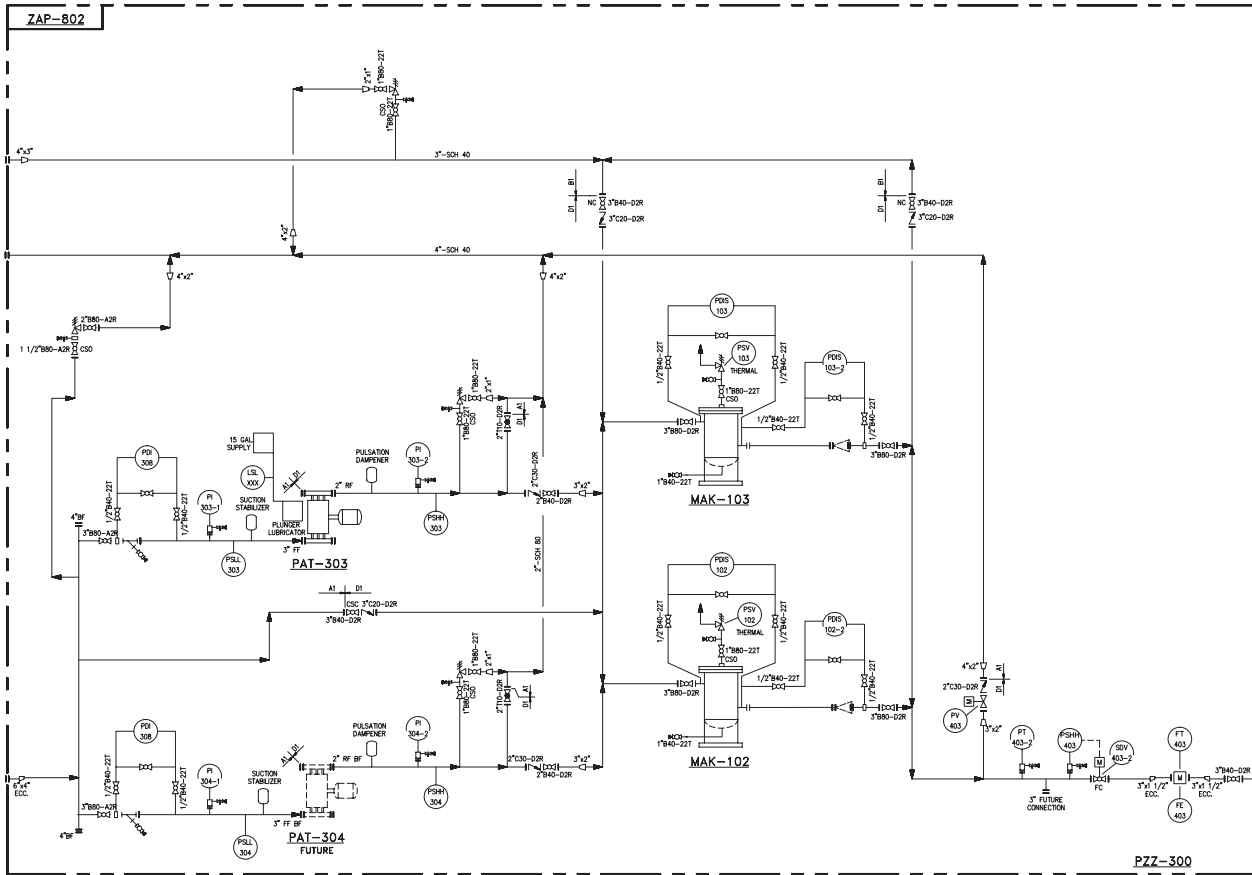

QTY PUMPS	FLOW (GPM)	DISCHARGE PRESSURE (PSIG)	LENGTH - X	WIDTH - Y	HEIGHT - Z	WEIGHT LBS
2	60	1500	40	12	12	14,000
2	120	1500	45	12	12	16,000
2	650	1000	55	12	12	24,000
2	1200	150	50	12	12	18,000

INTEGRATED FLOW SOLUTIONS 28377 Freeman Road, Katy, TX 77493 281-638-9870