

## Low Pressure Packaged Pump System

Integrated Flow Solutions Low Pressure Packaged Pump Systems are designed to transfer various industrial liquids (water, hydrocarbon, chemicals, etc.) from one location to another. The complete system includes centrifugal pump(s)/motor(s), suction/discharge piping, valving, instrumentation, controls, and is designed to minimize field assembly.

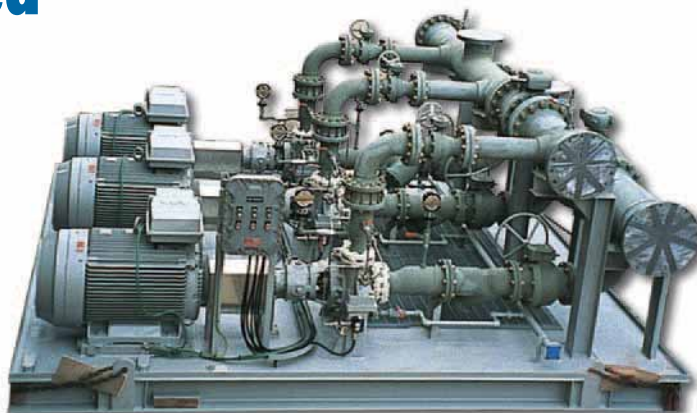

### Industries



POWER



OIL & GAS



GENERAL

### Benefits

- Single Source Accountability
- Pre-Packaged Modular Design Costs Less Than Component Based Site-Built Systems Reducing Overall Project Cost
- Minimizes Field Erection Time - Shorter Overall Project Delivery Schedule
- Complete System Function Testing Prior To Shipment
- 24/7 Customer Service

### Industry Standards

- Vessels Code Stamped ASME Section VIII & National Board Registered
- Piping Designed to ANSI B31.1/ANSI B31.3
- Pipe Fabrication to ASME Section IX
- Structural Steel Assembly Designed to AWS D1.1

### Standard Features

- Duplex Pump Configuration Providing 100% Standby
- Heavy Duty Ductile Iron Centrifugal Pumps with Mechanical Seal
- Pump Isolation Valves with Online Maintenance

### Standard Features (Continued)

- Discharge Check Valves for System Backflow Protection
- Non-Overloading 460 Volt TEFC Motors
- Hydrotesting of All Piping
- High Quality Industrial Coating System

### Optional Features

- Simplex & Triplex Pump Configurations
- ANSI B73 or API 610 Pumps
- All NEMA or IEC Rated Enclosures and Components for Class 1, Div. 1 or Div. 2 Electrical Areas
- Variable Frequency Drives (VFD)
- Microprocessor Controller with INTEGRAFLOW™ Control Software
- Intelligent VFD Control Systems for Sequential Starting of Multiple Motors
- Kooltronic™ VFD Cooling Device
- Panelview Operator Interface

### Additional Services

- Nationwide Service Network
- Utility System Optimization Studies
- Installation & Supervision
- Turn-Key Projects
- Equipment Leasing Program
- Extended Equipment Warranties

# Low Pressure Packaged Pump System

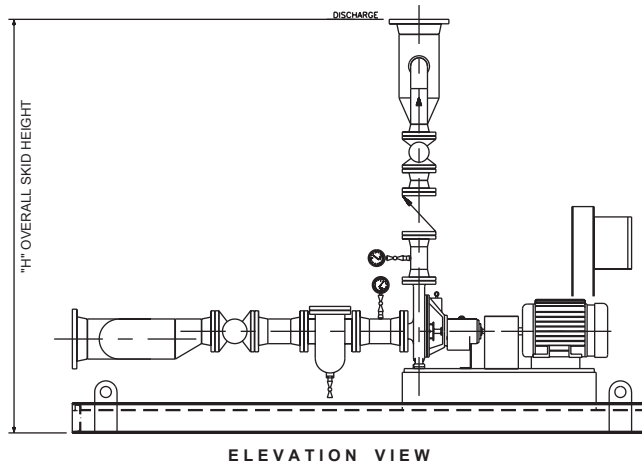
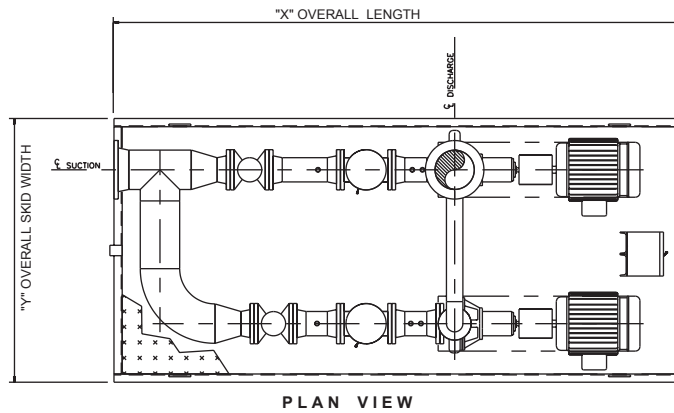
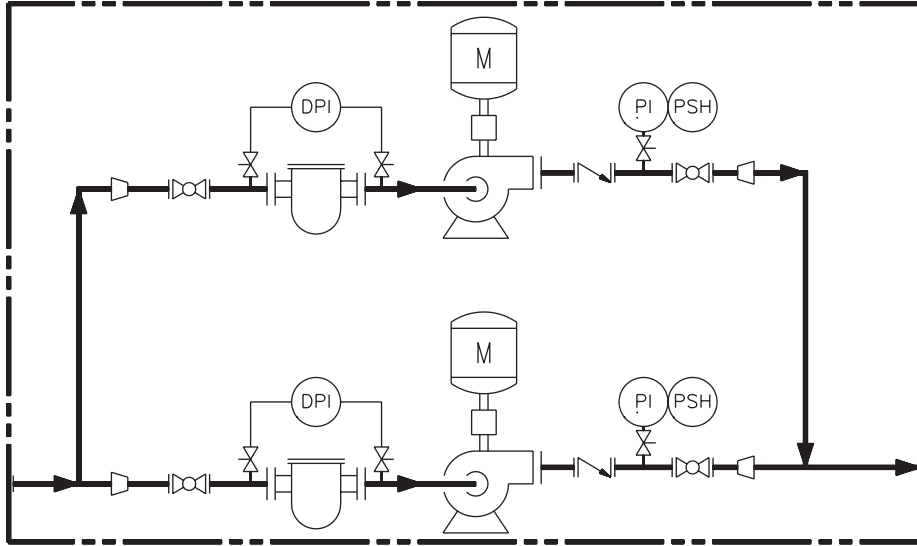

FLOW RATE (GPM)	PRESSURE (PSI)	LENGTH - X	WIDTH - Y	HEIGHT - Z	WEIGHT (LBS.)
50	100	8'	11'	14'	15,000
100	100	10'	11'	14'	20,000
750	100	12'	11'	14'	25,000
1,500	100	14'	11'	14'	30,000
3,000	100	16'	11'	14'	35,000