

## Super Sump Pumping System

Integrated Flow Solutions Super Sump Pumping Systems are complete single or double wall sump systems designed to capture various industrial liquid runoff including water, hydrocarbon, chemical, etc. Each Super Sump is fitted with leak detection, locking hatch for inspection, flame arrestor (for hydrocarbons), sump pump(s), electric motor(s), instrumentation, controls and is designed to minimize field assembly.



### Industries



POWER



OIL & GAS



GENERAL

### Benefits

- Single Source Accountability
- Pre-Packaged Modular Design Costs Less Than Component Based Site-Built Systems Reducing Overall Project Cost
- Minimizes Field Erection Time - Shorter Overall Project Delivery Schedule
- Complete System Function Testing Prior To Shipment
- 24/7 Customer Service

### Industry Standards

- Vessels Code Stamped ASME Section VIII & National Board Registered
- Piping Designed to ANSI B31.1/ANSI B31.3
- Pipe Fabrication to ASME Section IX
- Structural Steel Assembly Designed to AWS D1.1

### Standard Features

- Sump Materials of Carbon Steel, Fiberglass or 316SS
- Simplex or Duplex Heavy Duty Vertical Cast Iron Sump Pump(s)
- TEFC or XP Electric Motor Enclosure
- Motor Voltage - 230 or 460 Volt

### Standard Features (Continued)

- Double Wall Design with Dependable Leak Detection
- Below Grade Sump Inlets for Maximum Site Drainage
- Hydrotesting of Sump Vessel
- Lifting Lugs for Easy Installation
- Grit Blasted Epoxy Coated Sump Inside/Outside for Maximum Corrosion Protection

### Optional Features

- Across-the-Line Motor Starter Panels
- All NEMA or IEC Rated Enclosures and Components for Class 1, Div. 1 or Div. 2 Electrical Areas
- Panelview Operator Interface
- Microprocessor Controller with INTEGRAFLOW™ Control Software to Monitor Critical Functions & Provide Complete System Control
- Complete String Test of Package

### Additional Services

- Nationwide Service Network
- Installation & Supervision
- Turn-Key Projects
- Equipment Leasing Program
- Extended Equipment Warranties

# Super Sump Pumping System

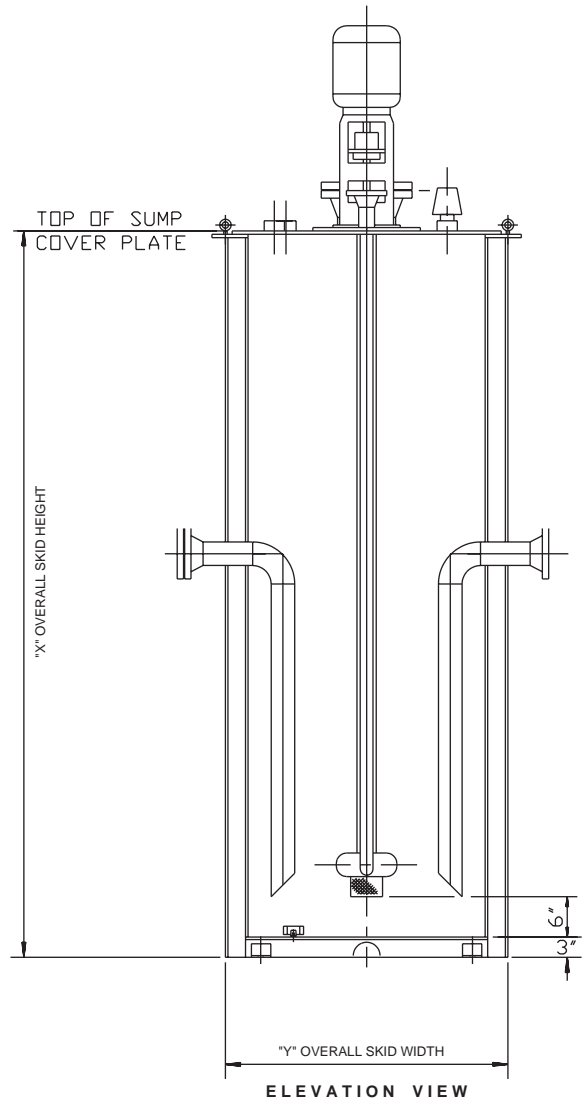
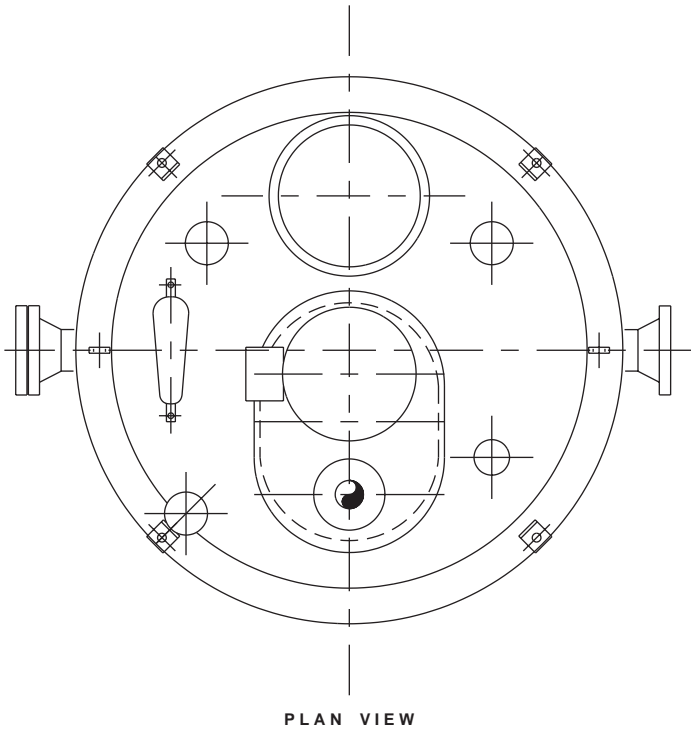

WORKING VOLUME - GALLONS	LENGTH - X	WIDTH - Y	WEIGHT - LBS.
300	6'	4'	4,500
750	8'	5'	6,500
1,500	10'	6'	9,000
3,000	16'	6'	12,000
5,000	16'	8'	15,000